

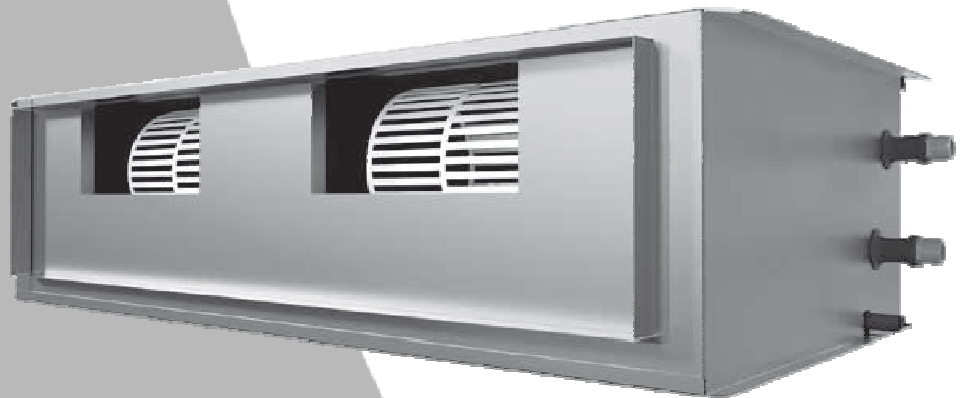

SERIES SOFFIO



TECHNICAL MANUAL

DUCTED
AIR
UNIT



CONTENTS

1-INTRODUCTION	5
2-APPLICATION LIMITS	5
3-CODES INTERPRETATION KEY	6
4-CONTROLS.....	6
5- TECHNICAL SPECIFICATIONS	7
6 - TECHNICAL DATA (AC motors)	8
6.1-2-pipe unit with 3-row coil	9
6.2-4-pipe unit with 3-row coil and auxiliary 1-row coil	10
7-TECHNICAL DATA (EC motors)	14
7.1-2-pipe unit with 3-row coil	14
7.2- 4-pipe unit with 3-row coil and auxiliary 1-row coil	15
8-DIMENSIONS AND WEIGHTS	18
8.1-Dimensions and weights of horizontal version (HC) with single panel (SP).....	18
8.2-Dimensions and weights of horizontal version (HC) with double panel (DP)	20
8.3-Dimensions and weights of vertical version (VC) with single panel (SP)	22
8.4-Dimensions and weights of vertical version (VD) with single panel (SP)	24
8.5-Hydraulic connections and coil volume.....	25
9-ACCESSORIES.....	26
9.1-Auxiliary coil with 1 or 2 rows (B1-B2)	28
9.2-Valves (V)	28
refer to the specific technical manual.....	30
9.3-Auxiliary condensate collection tray (VCS).....	31
9.4-Condensate drain pump (PSC).....	32
9.5-Static balancing and calibration valve (BLV)	33
9.6-Shut-off ball valve (SOV)	34
9.7-Flexible hoses (FLEX).....	35
9.8-Transformer for modulating valves (TR24)	35
9.9-Power relay board (ETBN-2.5A and ETBN-6A).....	36
9.10-Three-speed EC motor control board (SC3).....	36
9.11-Electrical heater (EH) and relay (EHR).....	37
9.12-Fluid-tight electrical panel (IPB).....	37

9.13-Flat flange (FP)	38
9.14-Return flange (FRAB)	39
9.15-Return flange (FRAL).....	40
9.16 -Return flange for vertical version (FRAV)	41
9.17-90° Plenum (P90)	42
9.18-Return air mixing plenum (PMA).....	43
9.19-Straight plenum (PD)	44
9.20-Plenum with spigot (PS)	45
9.21-Air regulation plenum (PRA)	46
9.22-Plenum with 3 or 4 row post-heating coil (PB3 – PB4).....	47
9.23-Plenum with electric heaters (PEH)	49
9.24-Delivery grille (GM2)	51
9.25-Return grille (GR).....	52
9.26-Decorative return grille (GRD)	53
9.27-Plenum with delivery grille (PGM2).....	54
9.28-Plenum with return grille (PGR)	55
9.29- Insulation for plenum (COIB)	56
9.30- Duct silencer (SL)	56
9.31-Filter (F)	57
9.32-Air return flange with pocket filter (FRAF6, FRAF7, FRAF8).....	58
10-Electrical connections.....	60
10.1-AC motor with ETBN 2.5A or ETBN-6A board	61
10.2-EC Motor	62

1-INTRODUCTION

The units of the SOFFIO series are designed for air conditioning in the residential and retail sectors, for indoor installation not exposed to freezing or otherwise extreme temperatures, in non-dusty, non-explosive and non-aggressive environments (in particular with regard to the aluminium fins and the galvanized coating and/or paint finishing of the metal plates). The manufacturer cannot be held liable for the consequences of incorrect use of the unit.

The units are designed to be ducted. Do not install them without ducting, as this might cause malfunction or damage to the machine.

The basic unit consists of a filter, a heat exchange section (coil and condensation tray) and a fan section (motor and fan). A wide variety of optional sections are also available as accessories (see the dedicated chapter), including optional filters, plenums and hydraulic accessories.

The SOFFIO units are available in the following variants:

- single panel and double panel versions
- versions with traditional three-speed motor (AC) and with low consumption motor (EC)

2-APPLICATION LIMITS

Electrical power supply	230V / 50 - 60Hz (1) (2)
Coil inlet water temperature	3 / 90°C
Maximum air delivery temperature (3)	50°C
Return air temperature	10 / 50°C

(1) +/-10% with respect to the nominal supply voltage. All technical data in this manual refer to 230V / 50Hz.

(2) For size 41 with AC motor, there are some limitations of the working range with 60Hz frequency

(3) In the case of water with a delivery flow temperature higher than 50°C, check the air delivery temperature using the TESI10 selection software.

	Minimum external pressure head (motor working range)				
	21	31	38	41	81
50Hz	0 Pa	0 Pa	0 Pa	0 Pa	0 Pa
60Hz	0 Pa	0 Pa	0 Pa	40 Pa	0 Pa

Working with low external heads, even within the motor's working range, could cause dripping from the coil during summertime operation (also depending on the degree of humidity in the environment). To prevent this, it is recommended to work at pressure heads of at least 40Pa and not exceeding the following flow rate values:

	Max air flow rate		
	21	31-38	41-81
	1250 cu.m/h	2300 cu.m/h	4500 cu.m/h

The units should only operate close to their limit operating values for short periods of time, because operation close to limit conditions for prolonged periods can reduce the normal lifetime of unit components.

3-CODES INTERPRETATION KEY

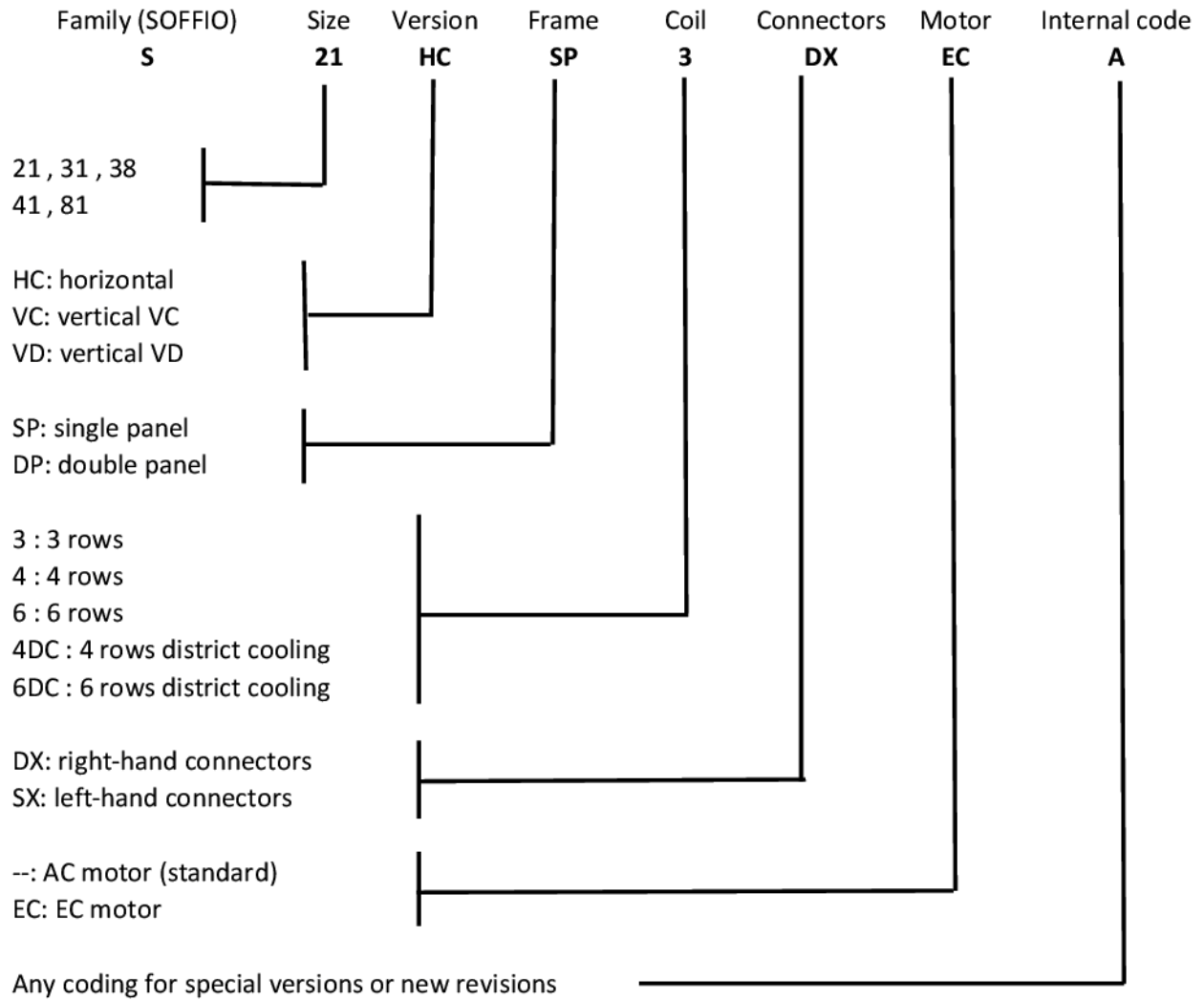

4-CONTROLS

The units of the SOFFIO series can be controlled via wall-mounted thermostats, with a temperature probe inside the wall thermostat or in the unit intake section.

However, it is recommended to use thermostats with wall temperature probes, rather than intake temperature probes, because this ensures more accurate temperature detection thanks to better positioning.

The controls for units with AC motors must have contacts for the three motor speeds sized for at least one inductive load, equal to the highest power draw from the motor. In the event that the control is unable to support this load, the use of a relay board such as ETBN-2.5A or ETBN-6A is recommended.

Direct connection (in parallel) of more than one unit with AC motor to the same control or to the same relay board is strictly not permitted. In this case, one relay board (such as the ETBN-2.5A or ETBN-6A board) must be used for each unit (or a single relay board with dedicated contacts for each unit).

	21	38	81
Input impedance 0/10V EC motor	90 kΩ	90 kΩ	50 kΩ
Input current 0/10V EC motor	0.11 mA	0.11 mA	0.2 mA

The controls for units with EC motor must have an output with 0/10V voltage signal sized to supply at least the current value shown in the table for each connected unit. It is possible to connect several units with EC motor in parallel to the same control, until the maximum current rating of that control is reached, without interposing other boards.

Using the SC3 accessory it is also possible to control the EC motor units using a traditional three-speed AC motor control.

For information on the proposed and approved controls for SOFFIO units, please refer to the dedicated literature. Should you intend to use other types of control, their compatibility should be carefully evaluated before using them

5- TECHNICAL SPECIFICATIONS

FRAME: made of 1.00-1.50mm thick galvanized sheet steel. This rugged structure prevents the propagation of vibration and comes complete with ceiling fixing brackets. Upon request, it can be paint-finished.

For the double panel version (DP), the frame is a sandwich panel with internal plate thickness of 0.6 - 0.8mm and external plate thickness of 1.50 - 0.80mm.

ACCESSIBILITY: the filter can be removed both from the bottom and from the sides, without any tools being needed (if some accessories are installed at the intake end, please refer to the specific chapter of the manual for more information). Accessibility to internal components is obtained by removing the lower panel. The fan unit plate can be removed without having to disconnect the ducting and the operation can be carried out from the bottom, without removing the sides or front of the machine.

FILTER: ISO COARSE class with ePM10 efficiency <50% (ISO 16890), 15mm thickness, in synthetic, not washable material. Other types on request.

FAN UNIT (AC motors): the fans have forward curved blades and dual intake centrifuges directly coupled to the motor. The auger is made of galvanized steel, the fan is made of aluminium. The motor and fans are balanced after assembly. The motor is mounted on rubber vibration damping mounts, degree of protection IP20 and has three speeds.

FAN UNIT (EC motors): the fans have forward curved blades and dual intake centrifuges directly coupled to the motor. The auger is made of PP, the fan is in galvanized steel (for sizes 21 and 38); galvanized steel auger and aluminium fan (for size 81). The motor and fans are balanced after assembly. The motor is mounted on rubber anti-vibration mounts, degree of protection IP00 (for size 21), IP44 (for size 38), IP20 (for size 81), 0-10V control signal.

COIL: made of diameter 3/8" copper tubing with high efficiency corrugated aluminium fins; manual air bleed valve at the top of the manifold. The connectors are supplied as standard on the right side, and optionally on the left (viewed from in front of the air flow). Nominal pressure PN8.

The (optional) direct expansion coils are made with diameter 5/16" copper tubing and are suitable for working with R410A refrigerant (up to 45bar). Other refrigerants on request.

CONDENSATE COLLECTION TRAY: made of galvanized steel sheet and painted to prevent the formation of rust. The drain pipe and the edges are welded to avoid leaks over time. The tray is externally insulated with thermal insulation and is installed to an angle in the direction of the drain pipe to avoid standing water.

INSULATION: made of 10mm thick polyurethane, class HF1 according to the UL94 standard (self-extinguishing and non-dripping). The thermo-acoustic insulation is protected from moisture and dust by a surface film.

For the double panel version (DP), the polyurethane insulation has a thickness of 20mm.

ELECTRICAL CONTROL PANEL: made of galvanized sheet steel or plastic and positioned on the opposite side with respect to the hydraulic connections. On request it can be built with a watertight plastic enclosure and positioned on the same side as the hydraulic connections.

6 - TECHNICAL DATA (AC motors)

This chapter lists the operating specifications of the units with 3-row main coils and auxiliary 1-row coils.

The main 4- and 6-row coils and auxiliary 2-row coils are also available from our selection software.

The main coils are optimized to work with a water temperature difference $dT = 5K$ or similar values.

The auxiliary coils are optimized to work with a water temperature difference $dT = 10K$ or similar values.

The 4-6 row main coils for District Cooling (DC) are also available from our selection software. These coils are optimized to work with a water temperature difference $dT = 9K$ and/or a water flow equal to about half the nominal flow of the standard main coils.

The sound level data refer to single panel units (SP). In double panel units (DP) the sound emission radiated from the structure is lower.

6.1-2-pipe unit with 3-row coil



														NON EUROVENT(*)		
		21			31			38			41			81		
Speed(E)		min	med	max	min	med	max	min	med	max	min	med	max	min	med	max
Air flow rate(E)	m ³ /h	500	750	850	1350	1500	1580	1600	1850	2000	2400	2740	3075	3000	3550	3950
Head (E)	Pa	23	50	65	41	50	56	38	50	59	37	50	62	37	50	70
COOLING - air 27 °C (dry bulb) , 19 °C w.b. - water inlet 7 °C, outlet 12 °C																
Total capacity (E)	kW	2.81	3.63	3.92	6.69	7.13	7.35	7.40	8.06	8.41	12.38	13.52	14.46	14.26	15.70	16.72
Sensitive capacity (E)	kW	2.25	3.02	3.29	5.50	5.93	6.15	6.20	6.85	7.20	10.12	11.12	11.99	11.87	13.30	14.32
Water flow rate	l/h	483	625	674	1150	1226	1264	1274	1385	1447	2134	2317	2484	2452	2701	2866
Δp (water) (E)	kPa	9.9	15.6	17.8	17.0	19.0	20.0	20.3	23.5	25.4	18.9	21.8	24.8	24.9	31.1	37.1
HEATING - air 20 °C - water inlet 45 °C, outlet 40 °C																
Capacity (E)	kW	3.18	4.29	4.69	7.79	8.40	8.72	8.80	9.72	10.25	14.28	15.70	17.11	16.81	18.86	20.41
Water flow rate	l/h	552	742	811	1348	1454	1507	1522	1682	1773	2475	2724	2956	2907	3267	3524
Δp (water) (E)	kPa	9.51	16.1	18.8	17.1	19.5	20.8	21.1	25.2	27.7	18.8	22.1	25.6	25.9	33.6	41.6
MOTOR ELECTRIC POWER DRAW																
Power draw (E)	W	100	140	165	175	195	230	243	275	308	411	486	540	680	750	920
Max power draw	A	0.8			1.3			1.6			2.5			4.5		
SOUND DATA																
Return + radiated sound power(E)	dB(A)	42	52	56	59	62	63	57	60	62	61	64	67	64	69	72
Delivery sound power (E)	dB(A)	48	59	63	61	64	66	63	66	68	64	68	71	68	73	76
Return + radiated sound pressure (**)	dB(A)	33	43	47	50	53	54	48	51	53	52	55	58	55	60	63
Delivery sound pressure (**)	dB(A)	39	50	54	52	55	57	54	57	59	55	59	62	59	64	67

(E)= EUROVENT certified services

(*) = size 81 is not part of any EUROVENT certification program

(**) = the sound pressure levels are lower than power levels by 9 dB(A) for a 100 m³ space and a reverberation time of 0.5 sec.

6.2-4-pipe unit with 3-row coil and auxiliary 1-row coil



														NON EUROVENT (*)		
		21			31			38			41			81		
Speed(E)		min	med	max	min	med	max	min	med	max	min	med	max	min	med	max
Air flow rate(E)	m ³ /h	500	750	850	1350	1500	1580	1600	1850	2000	2400	2740	3075	3000	3550	3950
Head (E)	Pa	23	50	65	41	50	56	38	50	59	37	50	62	37	50	70
COOLING - air 27 °C (dry bulb) , 19 °C w.b. - water inlet 7 °C, outlet 12 °C																
Total capacity (E)	kW	2.81	3.63	3.92	6.69	7.13	7.35	7.40	8.06	8.41	12.38	13.52	14.46	14.26	15.70	16.72
Sensitive capacity (E)	kW	2.25	3.02	3.29	5.50	5.93	6.15	6.20	6.85	7.20	10.12	11.12	11.99	11.87	13.30	14.32
Water flow rate	l/h	483	625	674	1150	1226	1264	1274	1385	1447	2134	2317	2484	2452	2701	2866
Δp (water) (E)	kPa	9.9	15.6	17.8	17.0	19.0	20.0	20.3	23.5	25.4	18.9	21.8	24.8	24.9	31.1	37.1
HEATING - air 20 °C - water inlet 65°C, outlet 55°C																
Capacity (E)	kW	2.63	3.32	3.58	6.23	6.52	6.73	6.77	7.37	7.71	11.77	12.54	13.41	13.18	14.61	15.50
Water flow rate	l/h	229	290	312	543	569	586	591	642	671	1025	1090	1167	1154	1271	1351
Δp (water) (E)	kPa	1.9	2.8	3.2	4.3	4.6	4.9	4.9	5.7	6.2	5.8	6.5	7.3	7.1	8.5	9.6
MOTOR ELECTRIC POWER DRAW																
Power draw (E)	W	100	140	165	175	195	230	243	275	308	411	486	540	680	750	920
Max power draw	A	0.8			1.3			1.6			2.5			4.5		
SOUND DATA																
Return + radiated sound power(E)	dB(A)	42	52	56	59	62	63	57	60	62	61	64	67	64	69	72
Delivery sound power (E)	dB(A)	48	59	63	61	64	66	63	66	68	64	68	71	68	73	76
Return + radiated sound pressure (**)	dB(A)	33	43	47	50	53	54	48	51	53	52	55	58	55	60	63
Delivery sound pressure (**)	dB(A)	39	50	54	52	55	57	54	57	59	55	59	62	59	64	67

(E) = EUROVENT certified services

(*) = size 81 is not part of any EUROVENT certification program

(**) = the sound pressure levels are lower than power levels by 9 dB(A) for a 100 m³ space and a reverberation time of 0.5 sec.

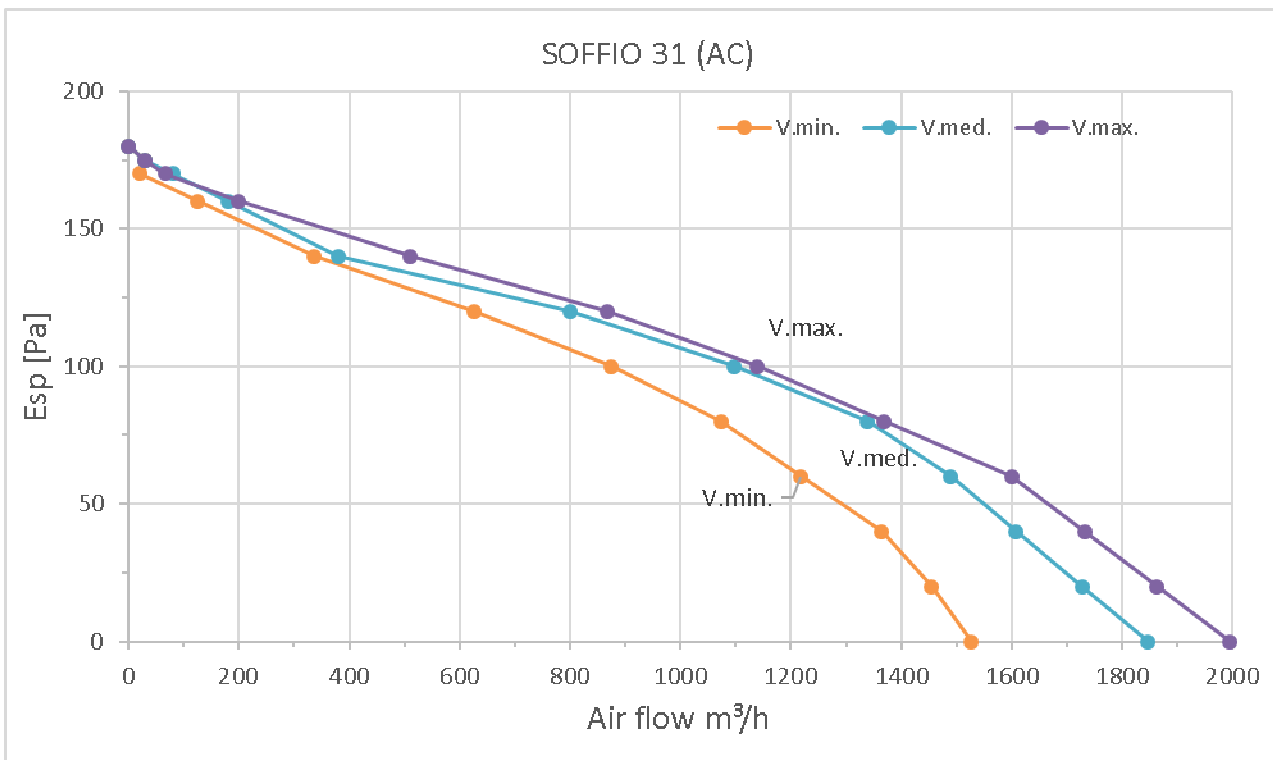
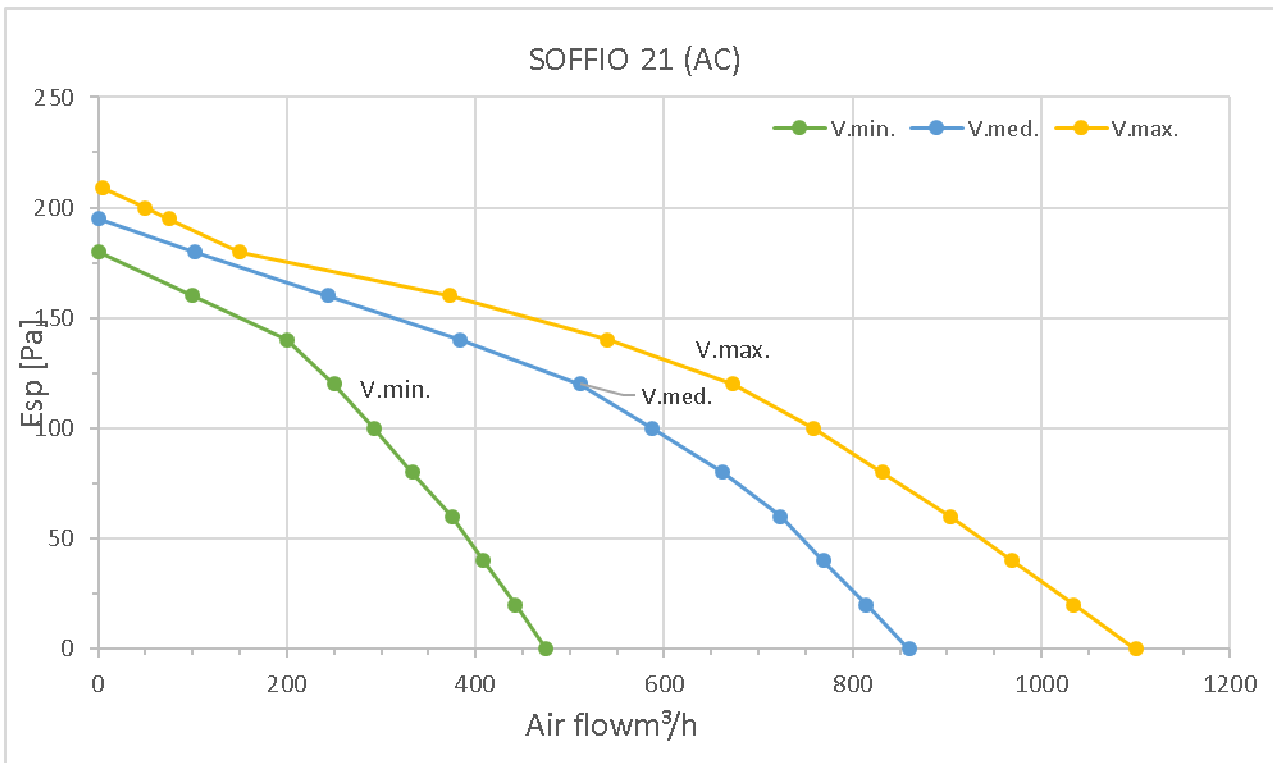

SOFFIO

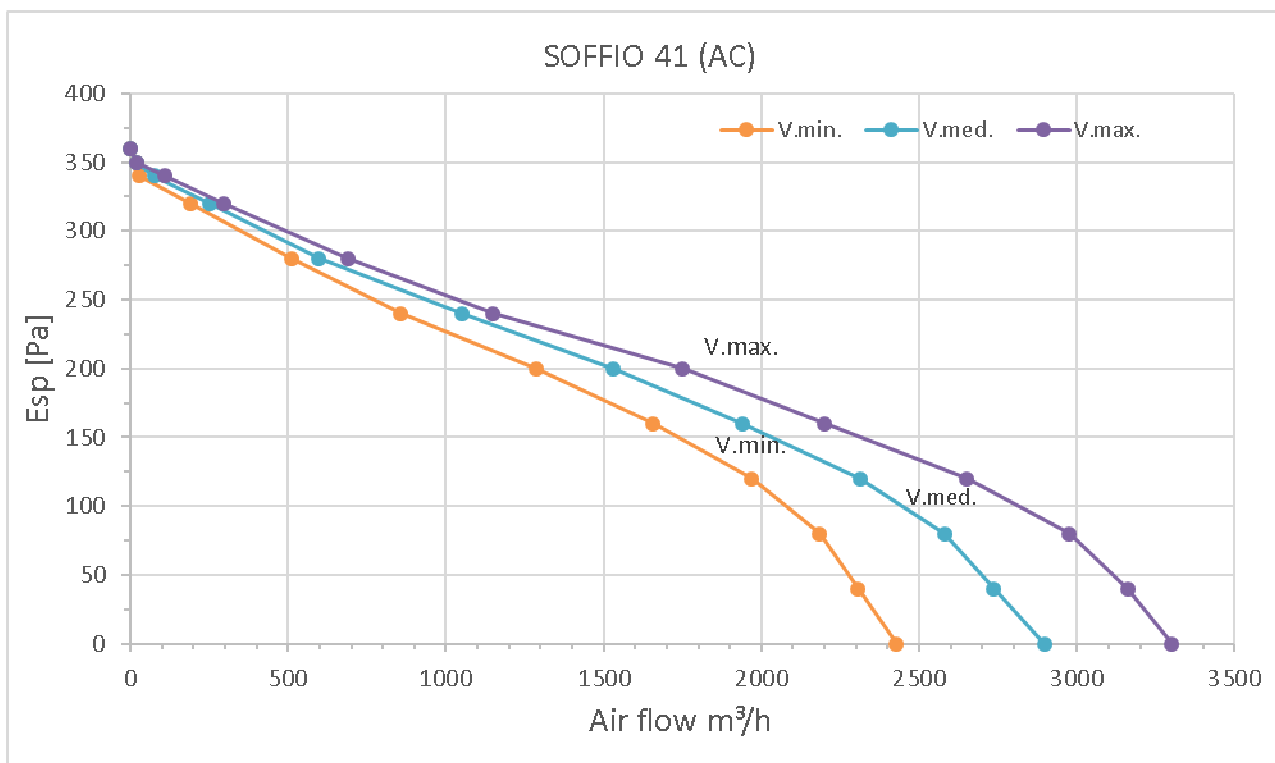
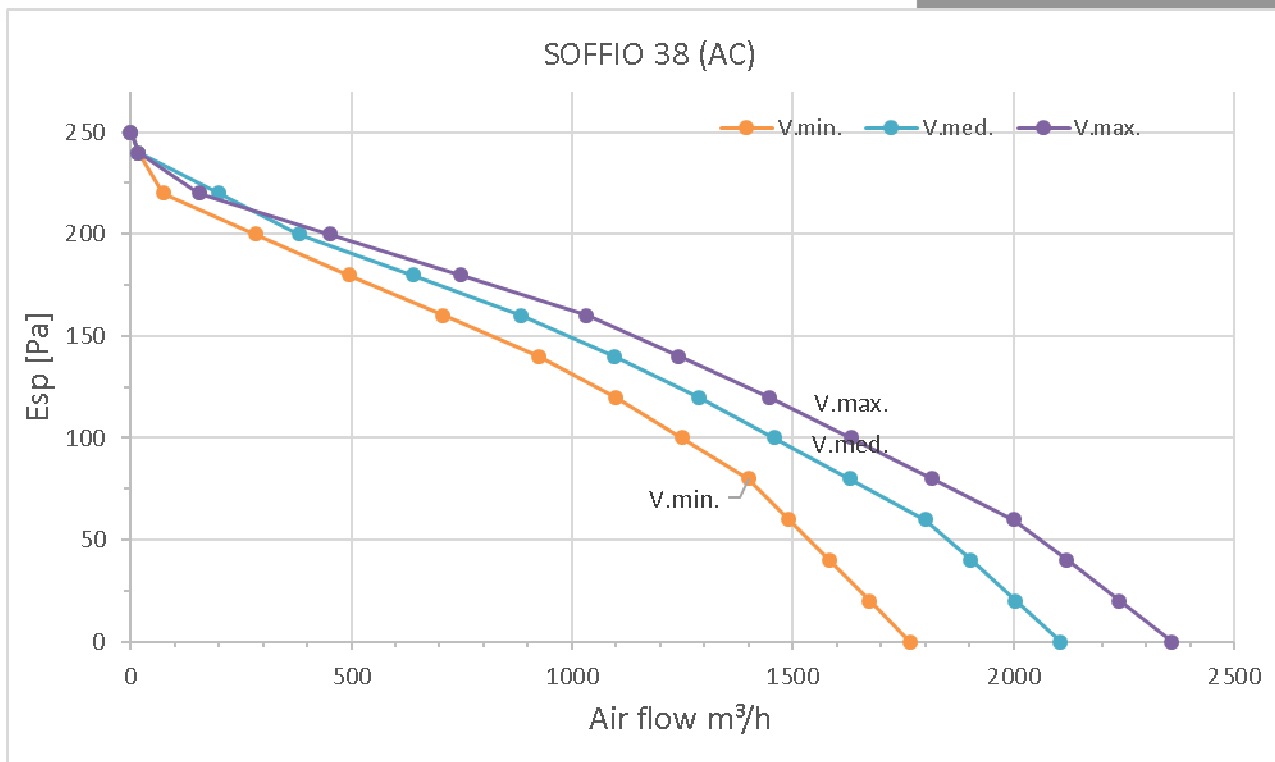

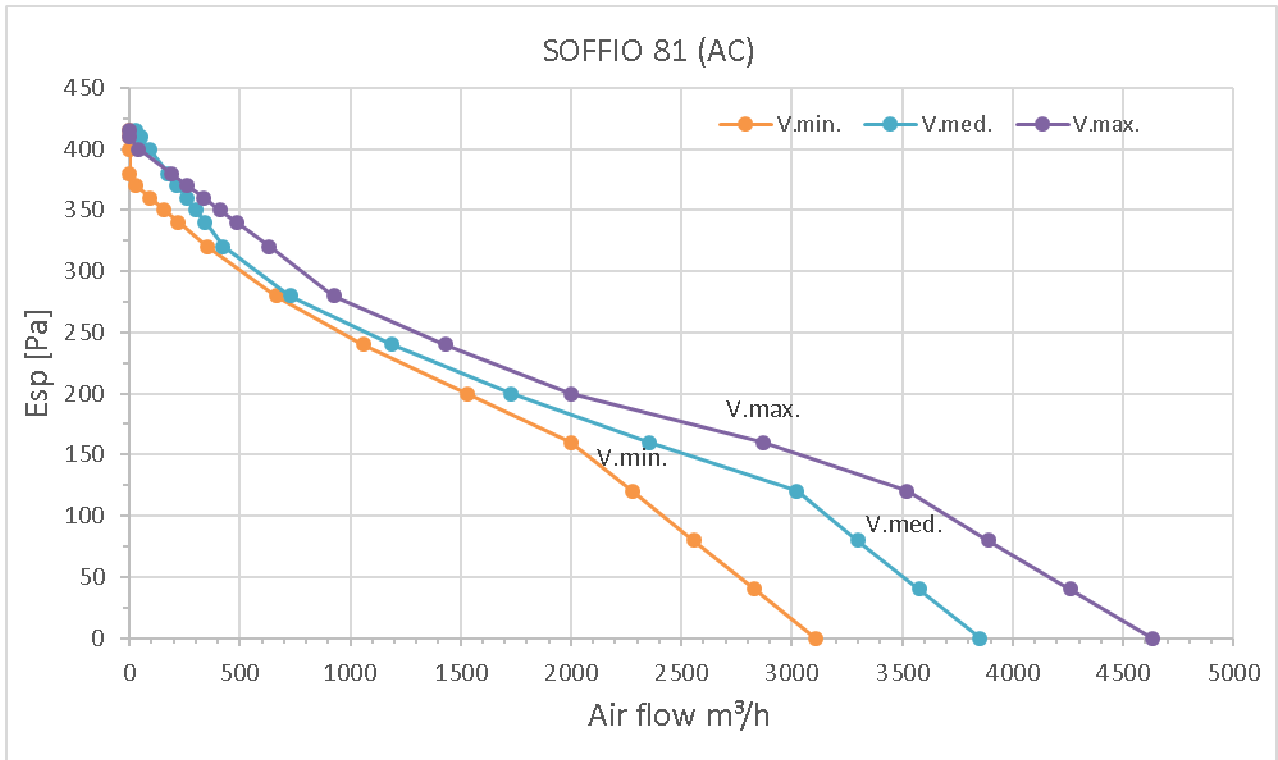

7-TECHNICAL DATA (EC motors)

This chapter lists the operating specifications of the units with 3-row main coils and auxiliary coils with 1 row. The main 4- and 6-row coils and auxiliary 2-row coils are also available from our selection software. The main coils are optimized to work with a water temperature difference $dT = 5K$ or similar values. The auxiliary coils are optimized to work with a temperature drop over water $dT = 10K$ or similar values. 4-6 rows main coils for District Cooling (DC) are also available in our selection software. These coils are optimized to work with a water temperature difference $dT = 9K$ and/or a water flow equal to about half the nominal flow of the standard main coils.

The sound level data refer to single panel units (SP). In double panel units (DP) the sound emission radiated from the structure is lower.

7.1-2-pipe unit with 3-row coil



		21			38			NON EUROVENT (*)		
		81								
Speed (Drive voltage)(E)	V	3	5	10	5	7	10	5	7	10
Air flow rate (E)	m ³ /h	550	850	950	1210	1550	1780	2970	3550	4090
Head (E)	Pa	20	50	130	30	50	68	35	50	70
COOLING - air 27 °C (dry bulb) , 19 °C w.b. - water inlet 7 °C, outlet 12 °C										
Total capacity (E)	kW	3.00	3.90	4.20	6.25	7.26	7.91	14.14	15.70	17.06
Sensitive capacity (E)	kW	2.40	3.30	3.60	5.10	6.10	6.70	11.77	13.30	14.61
Water flow rate	l/h	514	674	719	1074	1250	1359	2433	2701	2923
Δp (water) (E)	kPa	11.0	17.8	19.9	15.0	20.3	23.5	23.8	28.7	32.9
HEATING - air 20 °C - water inlet 45 °C, outlet 40 °C										
Capacity (E)	kW	3.40	4.70	5.07	7.20	8.61	9.50	16.68	18.86	20.82
Water flow rate	l/h	592	811	876	1246	1490	1646	2884	3267	3595
Δp (water) (E)	kPa	10.8	18.8	21.5	14.9	21.1	25.2	24.5	30.5	36.1
MOTOR ELECTRIC POWER DRAW										
Power draw (E)	W	26	95	169	80	160	245	312	510	770
Max power draw	A	1.3			1.7			3.8		
SOUND DATA										
Return + radiated sound power(E)	dB(A)	49	58	62	57	62	65	66	71	73
Delivery sound power (E)	dB(A)	53	62	66	59	65	68	70	74	77
Return + radiated sound pressure (**)	dB(A)	40	49	53	48	53	56	57	62	64
Delivery sound pressure (**)	dB(A)	44	53	57	50	56	59	61	65	68

(E)= EUROVENT certified services

(*) = size 81 is not part of any EUROVENT certification program

(**) = the sound pressure levels are lower than power levels by 9 dB(A) for a 100 m³ space and a reverberation time of 0.5 sec.

7.2- 4-pipe unit with 3-row coil and auxiliary 1-row coil



		21			38			NON EUROVENT (*)		
		81								
Speed (Drive voltage)(E)	V	3	5	10	5	7	10	5	7	10
Air flow rate(E)	m3/h	550	850	950	1210	1550	1780	2970	3550	4090
Head (E)	Pa	20	50	130	30	50	68	35	50	70
COOLING - air 27 °C (dry bulb) , 19 °C w.b. - water inlet 7 °C, outlet 12 °C										
Total capacity (E)	kW	3.00	3.90	4.20	6.25	7.26	7.91	14.14	15.70	17.06
Sensitive capacity (E)	kW	2.40	3.30	3.60	5.10	6.10	6.70	11.77	13.30	14.61
Water flow rate	l/h	514	674	719	1074	1250	1359	2433	2701	2923
Δp (water) (E)	kPa	11.0	17.8	19.9	15.0	20.3	23.5	23.8	28.7	32.9
HEATING - air 20 °C - water inlet 65°C, outlet 55°C										
Capacity (E)	kW	2.80	3.60	3.80	5.83	6.63	7.21	13.08	14.61	15.81
Water flow rate	l/h	243	312	332	509	578	628	1145	1271	1378
Δp (water) (E)	kPa	2.1	3.2	3.6	3.8	4.9	5.7	7.1	8.5	9.8
MOTOR ELECTRIC POWER DRAW										
Power draw (E)	W	26	95	169	80	160	245	312	510	770
Max power draw	A	1.3			1.7			3.8		
SOUND DATA										
Return + radiated sound power(E)	dB(A)	49	58	62	57	62	65	66	71	73
Delivery sound power (E)	dB(A)	53	62	66	59	65	68	70	74	77
Return + radiated sound pressure (**)	dB(A)	40	49	53	48	53	56	57	62	64
Delivery sound pressure (**)	dB(A)	44	53	57	50	56	59	61	65	68

(E)= EUROVENT certified services

(*) = size 81 is not part of any EUROVENT certification program

(**) = the sound pressure levels are lower than power levels by 9 dB(A) for a 100 m3 space and a reverberation time of 0.5 sec.

SOFFIO

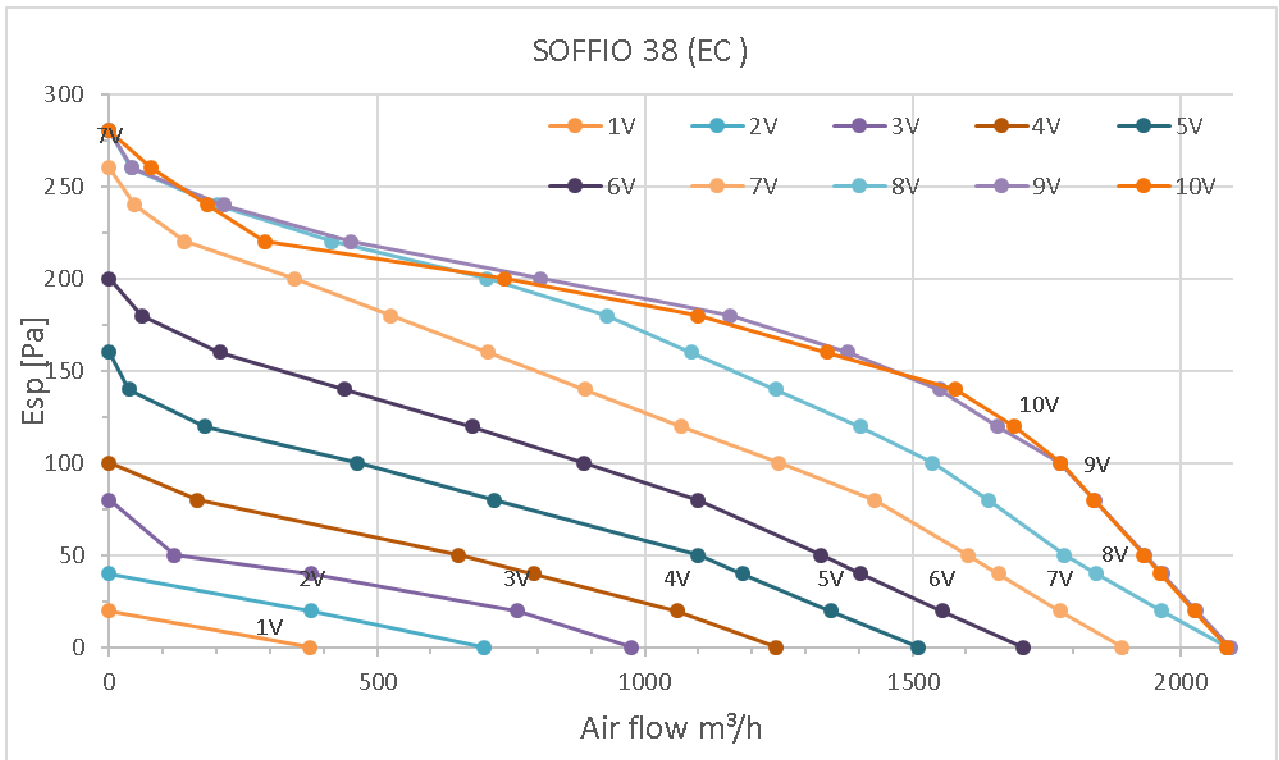
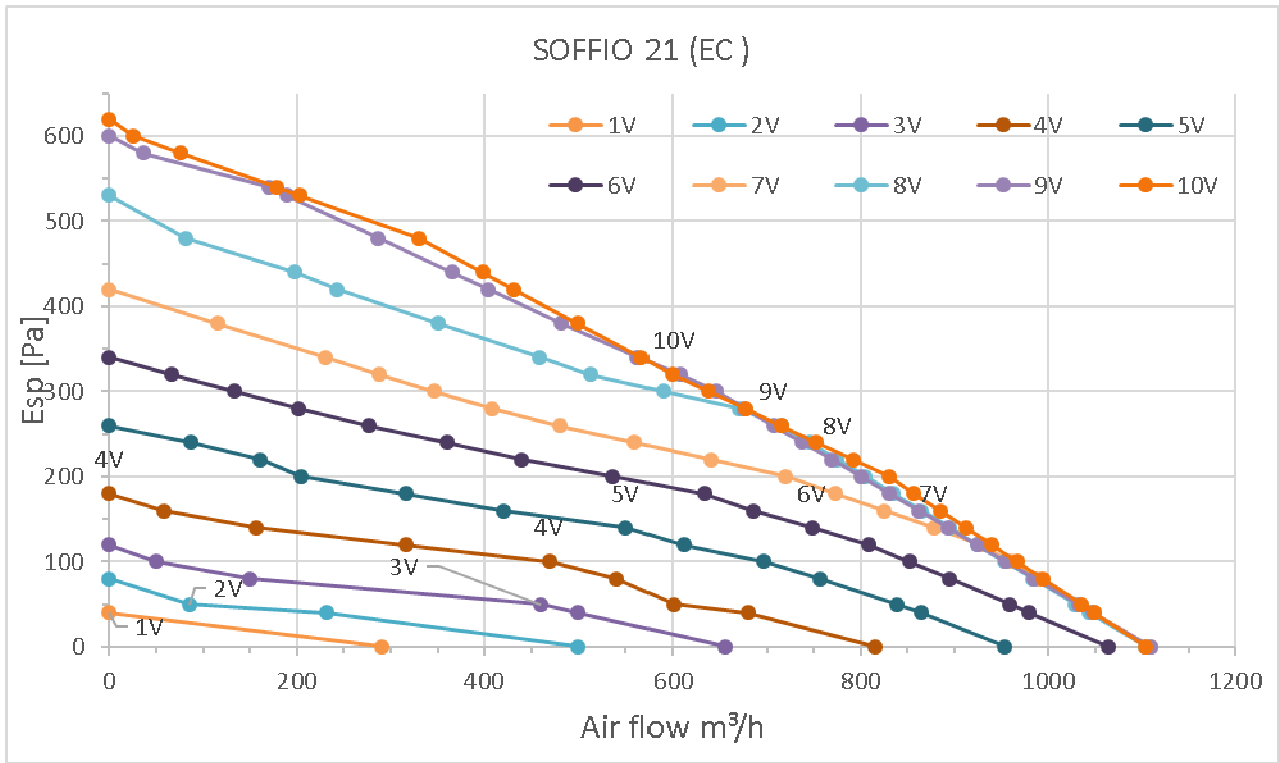

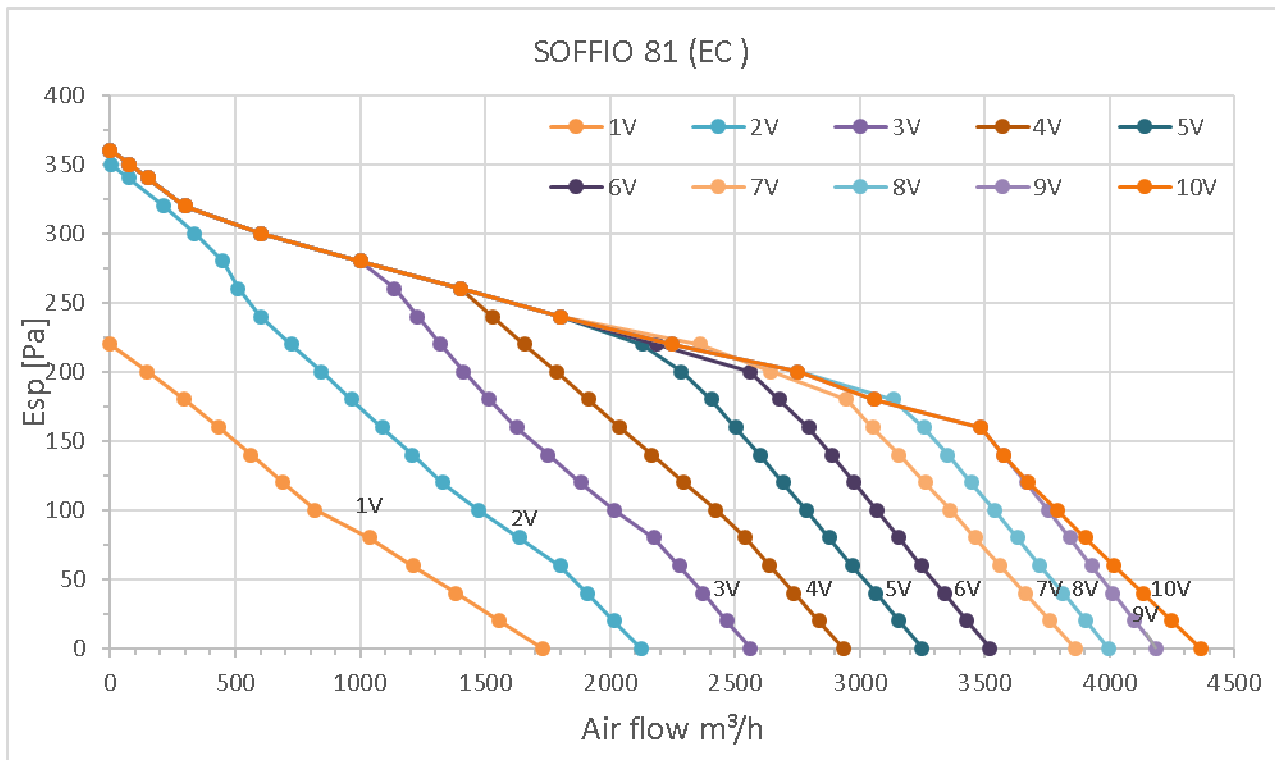

8-DIMENSIONS AND WEIGHTS

8.1-Dimensions and weights of horizontal version (HC) with single panel (SP)

Standard outfitting (right-hand connections)

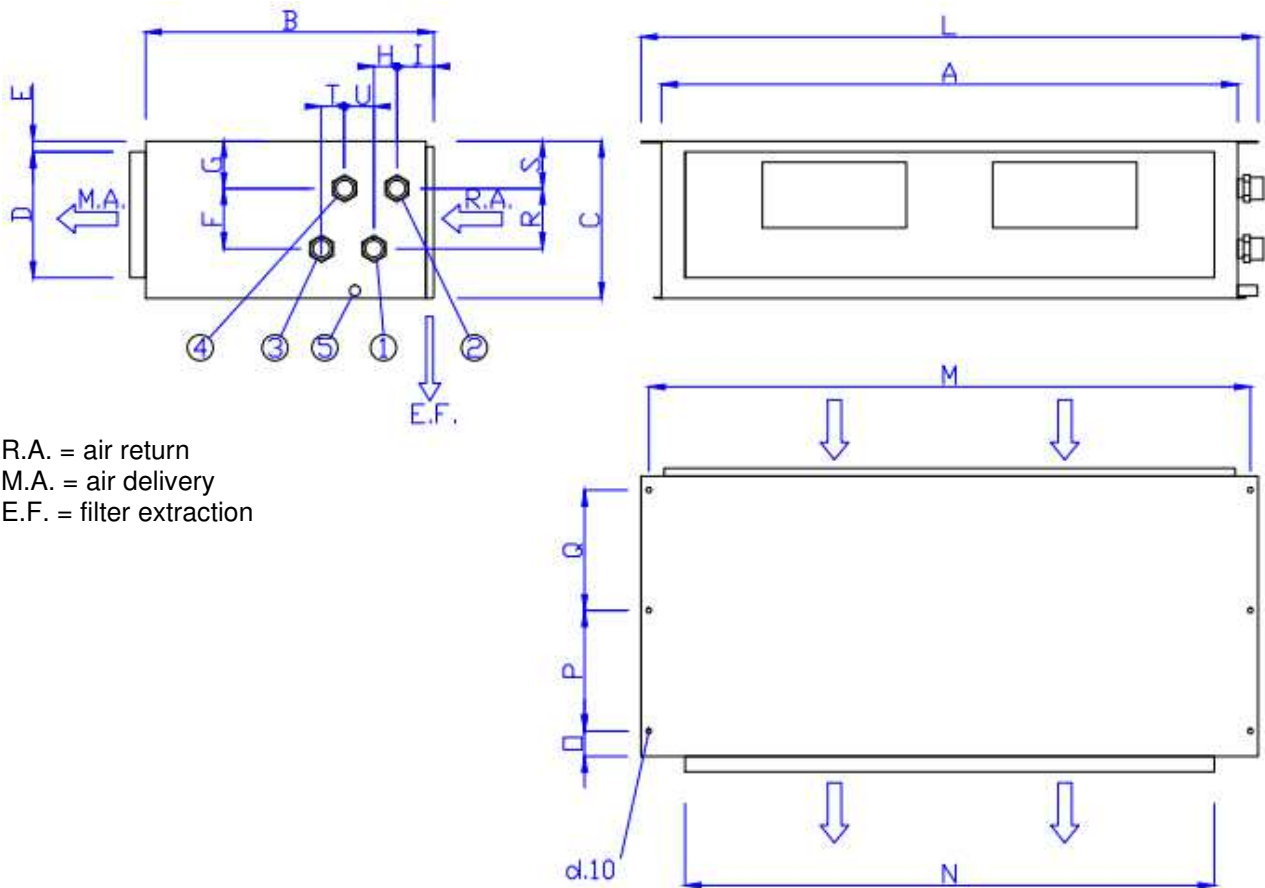

R.A. = air return
M.A. = air delivery
E.F. = filter extraction

Optional outfitting (left-hand connections)

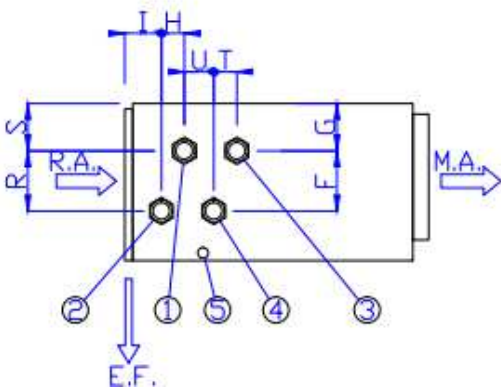

1	Main coil IN
2	Main coil OUT
3	Auxiliary coil IN
4	Auxiliary coil OUT
5	Condensate drain

	DIMENSIONS (mm)						DIMENSIONS (mm)				
	21	31	38	41	81		21	31	38	41	81
A	660	1100	1100	1650	1650	M	708	1148	1148	1698	1698
B	550	550	550	650	650	N	570	1010	1010	1560	1560
C	300	300	300	375	375	O	50	50	50	60	60
D	240	240	240	300	300	P	230	230	230	275	275
E	20	20	20	25	25	Q	230	230	230	275	275
F	120	120	120	120	120	R	115	115	115	190	190
G	90	90	90	125	125	S	90	90	90	90	90
H	44	44	44	44	44	T	30	30	30	30	30
I	70	70	70	70	70	U	68	68	68	68	68
L	738	1178	1178	1728	1728						

	UNIT WEIGHT (kg)				
	21	31	38	41	81
3 rows	38	54	55	90	94
3 rows +1 (4 pipes)	40	57	58	94	98
3 rows +2 (4 pipes)	42	60	61	98	102
4 rows	40	57	58	94	98
4 rows +1 (4 pipes)	42	60	61	98	102
4 rows +2 (4 pipes)	44	63	64	102	106
6 rows	44	63	64	102	106

8.2-Dimensions and weights of horizontal version (HC) with double panel (DP)

Standard outfitting (right-hand connections)

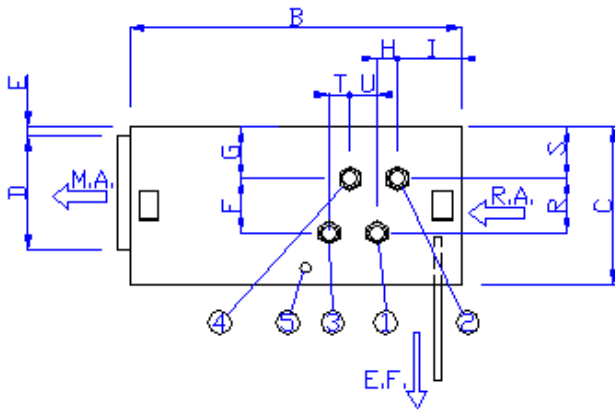

R.A. = air return
M.A. = air delivery
E.F. = filter extraction

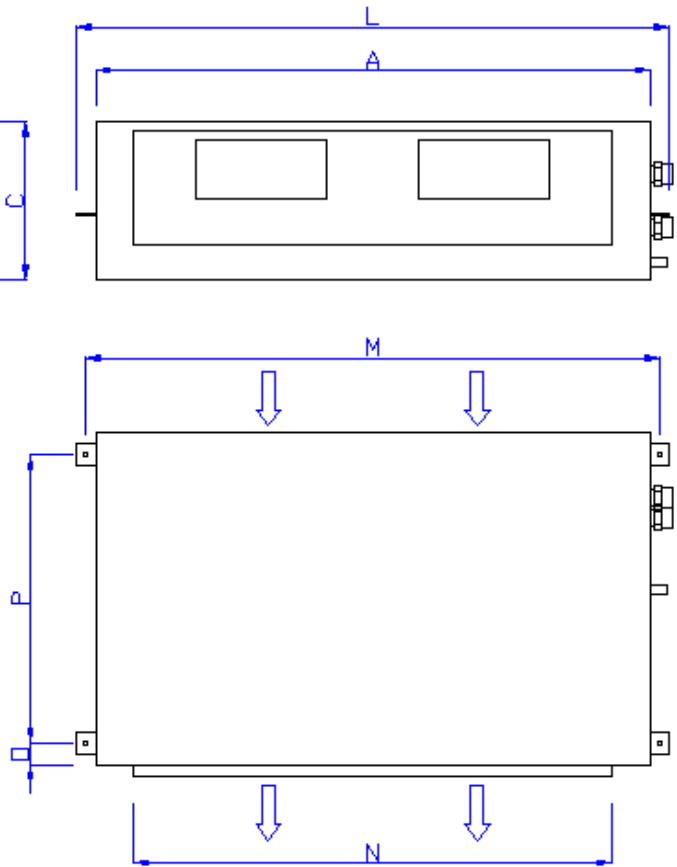

Optional outfitting (left-hand connections)

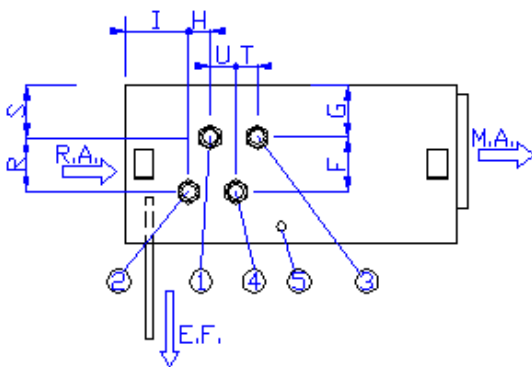

1	Main coil IN
2	Main coil OUT
3	Auxiliary coil IN
4	Auxiliary coil OUT
5	Condensate drain

	DIMENSIONS (mm)						DIMENSIONS (mm)				
	21	31	38	41	81		21	31	38	41	81
A	730	1170	1170	1720	1720	M	772	1212	1212	1762	1762
B	700	700	700	800	800	N	570	1010	1010	1560	1560
C	335	335	335	410	410	O	45	45	45	45	45
D	240	240	240	300	300	P	610	610	610	710	710
E	20	20	20	25	25	Q	-	-	-	-	-
F	115	115	115	190	190	R	120	120	120	190	190
G	120	120	120	110	110	S	120	120	120	110	110
H	44	44	44	44	44	T	30	30	30	30	30
I	135	135	135	135	135	U	68	68	68	68	68
L	810	1250	1250	1800	1800						

	UNIT WEIGHT (kg)				
	21	31	38	41	81
3 rows	49	70	72	117	122
3 rows +1 (4 pipes)	52	74	75	122	127
3 rows +2 (4 pipes)	55	78	79	127	133
4 rows	52	74	75	122	127
4 rows +1 (4 pipes)	55	78	79	127	133
4 rows +2 (4 pipes)	57	82	83	133	138
6 rows	57	82	83	133	138

8.3-Dimensions and weights of vertical version (VC) with single panel (SP)

Standard outfitting (right-hand connections)

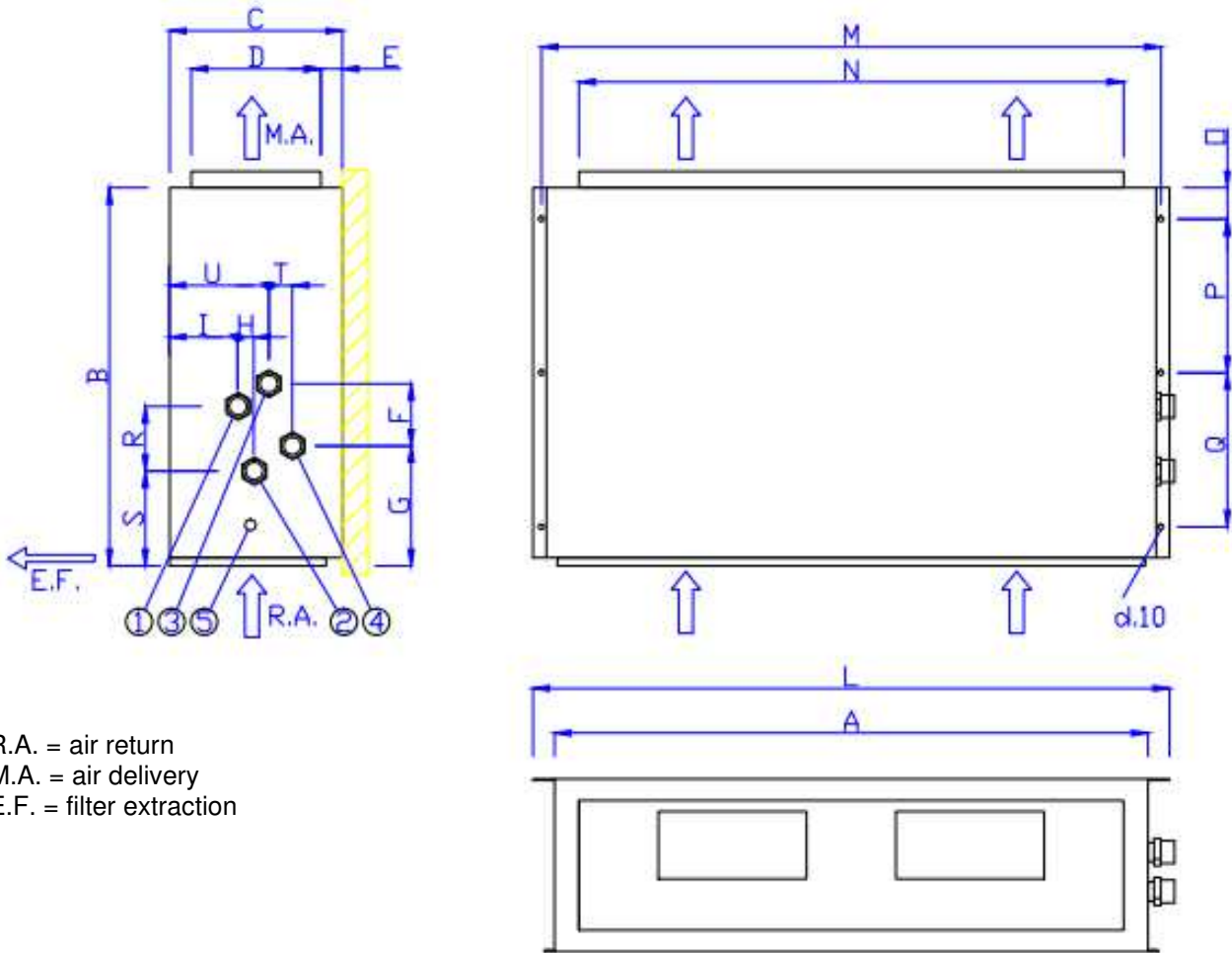

R.A. = air return
M.A. = air delivery
E.F. = filter extraction

Optional outfitting (left-hand connections)

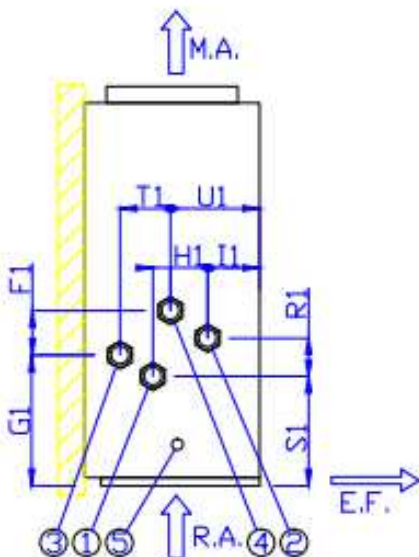

1	Main coil IN
2	Main coil OUT
3	Auxiliary coil IN
4	Auxiliary coil OUT
5	Condensate drain

	DIMENSIONS (mm)						DIMENSIONS (mm)				
	21	31	38	41	81		21	31	38	41	81
A	660	1100	1100	1650	1650	M	708	1148	1148	1698	1698
B	700	700	700	900	900	N	570	1010	1010	1560	1560
C	320	320	320	375	375	O	60	60	60	60	60
D	240	240	240	300	300	P	285	285	285	385	385
E	20	20	20	25	25	Q	285	285	285	385	385
F	115	115	115	115	115	R	120	120	120	181	181
F1	82	82	82	82	82	R1	69	69	69	131	131
G	222	222	222	284	284	S	175	175	175	206	206
G1	240	240	240	300	300	S1	200	200	200	231	231
H	30	30	30	73	73	T	44	44	44	44	44
H1	68	68	68	68	68	T1	94	94	94	94	94
I	128	128	128	140	140	U	184	184	184	217	217
I1	91	91	91	105	105	U1	160	160	160	193	193
L	740	1180	1180	1730	1730						

	UNIT WEIGHT (kg)				
	21	31	38	41	81
3 rows	40	57	58	94	98
3 rows +1 (4 pipes)	42	60	61	98	102
3 rows +2 (4 pipes)	44	63	64	102	106
4 rows	42	60	61	98	102
4 rows +1 (4 pipes)	44	63	64	102	106
4 rows +2 (4 pipes)	46	66	67	106	110
6 rows	46	66	67	106	110

8.4-Dimensions and weights of vertical version (VD) with single panel (SP)

Standard outfitting (right-hand connections)

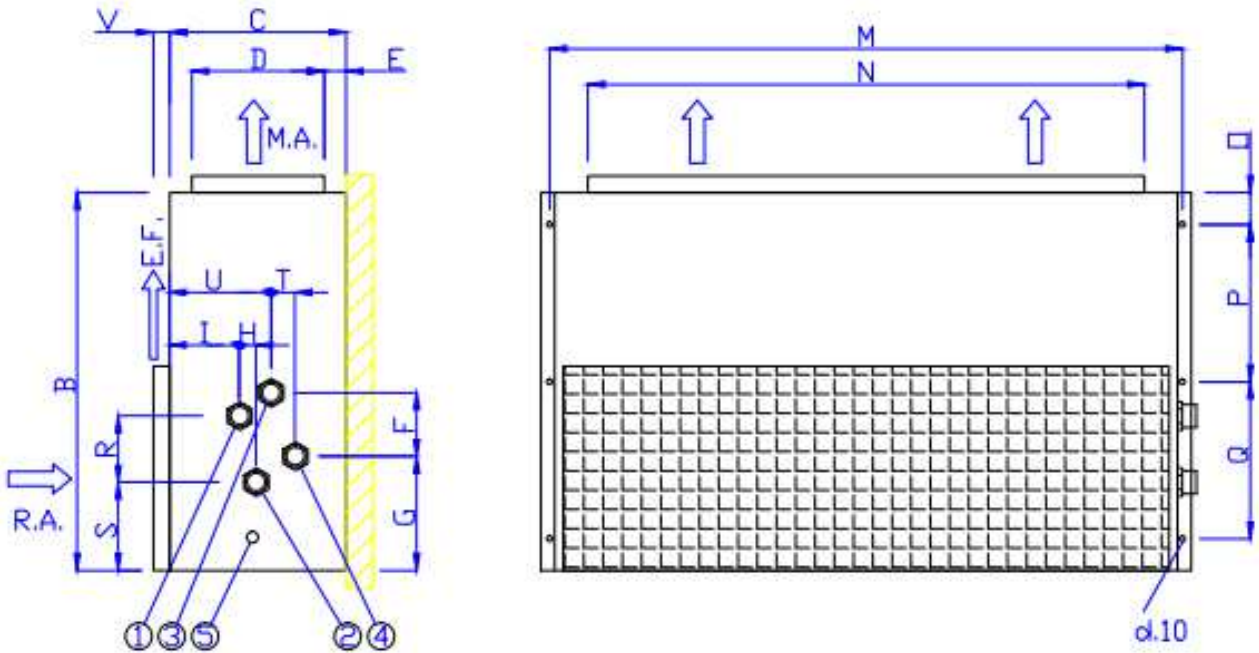

R.A. = air return
 M.A. = air delivery
 E.F. = filter extraction

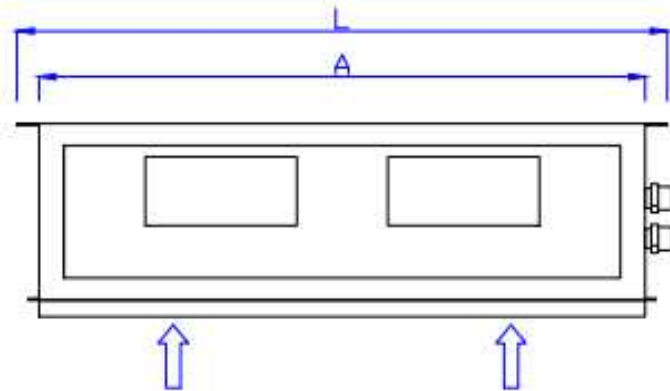

Optional outfitting (left-hand connections)

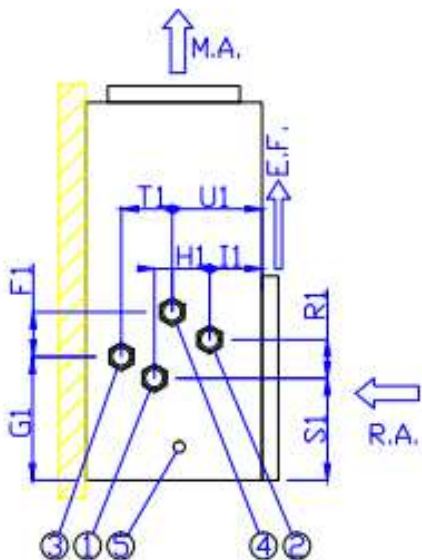

1	Main coil IN
2	Main coil OUT
3	Auxiliary coil IN
4	Auxiliary coil OUT
5	Condensate drain

	DIMENSIONS (mm)						DIMENSIONS (mm)				
	21	31	38	41	81		21	31	38	41	81
A	660	1100	1100	1650	1650	M	708	1148	1148	1698	1698
B	685	685	685	885	885	N	570	1010	1010	1560	1560
C	320	320	320	375	375	O	60	60	60	60	60
D	240	240	240	300	300	P	285	285	285	385	385
E	20	20	20	25	25	Q	285	285	285	385	385
F	115	115	115	115	115	R	120	120	120	181	181
F1	82	82	82	82	82	R1	69	69	69	131	131
G	222	222	222	284	284	S	160	160	160	191	191
G1	225	225	225	285	285	S1	185	185	185	216	216
H	30	30	30	73	73	T	44	44	44	44	44
H1	68	68	68	68	68	T1	94	94	94	94	94
I	128	128	128	140	140	U	184	184	184	217	217
I1	91	91	91	105	105	U1	160	160	160	193	193
L	740	1180	1180	1730	1730	V	30	30	30	30	30

	UNIT WEIGHT (kg)				
	21	31	38	41	81
3 rows	40	57	58	94	98
3 rows +1 (4 pipes)	42	60	61	98	102
3 rows +2 (4 pipes)	44	63	64	102	106
4 rows	42	60	61	98	102
4 rows +1 (4 pipes)	44	63	64	102	106
4 rows +2 (4 pipes)	46	66	67	106	110
6 rows	46	66	67	106	110

8.5-Hydraulic connections and coil volume

		HYDRAULIC CONNECTIONS				
		21	31	38	41	81
1	Main coil IN	3/4"	3/4"	3/4"	1"	1"
2	Main coil OUT	3/4"	3/4"	3/4"	1"	1"
3	Auxiliary coil IN	3/4"	3/4"	3/4"	3/4"	3/4"
4	Auxiliary coil OUT	3/4"	3/4"	3/4"	3/4"	3/4"
5	Condensate drain	20mm	20mm	20mm	25mm	25mm
	Direct liquid exp. R410A (welding)	d.6	d.10	d.10	d.16	d.16
	Direct gas exp. R410A (welding)	d.10	d.16	d.16	d.18	d.18

	COIL INSIDE VOLUME (litres)				
	21	31	38	41	81
3 rows	1.1	2.0	2.0	4.0	4.0
4 rows	1.5	2.7	2.7	5.4	5.4
6 rows	2.2	4.0	4.0	8.1	8.1
1 row auxiliary	0.4	0.7	0.7	1.3	1.3
2 rows auxiliary	0.7	1.3	1.3	2.7	2.7
4 row direct exp. R410A	1.0	1.8	1.8	3.6	3.6

9-ACCESSORIES

The following accessories are available:

		HYDRAULIC ACCESSORIES	HC/VC/VD	A/K/B
1	B1-B2	1- or 2-row auxiliary coil for 4-pipe systems	HC/VC/VD	A
2	V	Valve (for the VBD dynamic balancing valve, see the specific manual)	HC/VC/VD	K
3	VCS	Auxiliary condensate collection tray for valves	HC/VC/VD	K
4	PSC	Condensate drain pump	HC/VC/VD	K
5	BLV	Static balancing and calibration valve	HC/VC/VD	K
6	SOV	Shut-off ball valves	HC/VC/VD	K
7	FLEX	Flexible hoses for hydraulic connections	HC/VC/VD	K
		ELECTRICAL ACCESSORIES		
8	TR24	Transformer for modulating valve	HC/VC/VD	A
9	ETBN-2.5A / 6A	Power relay board	HC/VC/VD	A
10	SC3	Three-speed EC motor control board	HC/VC/VD	A
11	EH - EHR	Electrical heater - relay for electrical heaters	HC	A
12	IPB	Fluid-tight electrical panel	HC/VC/VD	A
		AERAILIC ACCESSORIES		
13	FP	Flat flange (return or delivery)	HC/VC/VD	A
14	FRAB	Return flange with filter extraction from below	HC	A
15	FRAL	Return flange with filter extraction from the side	HC	A
16	FRAV	Return flange with filter extraction from the side	VC/VD	A
17	P90	90° plenum (return or delivery)	HC/VC/VD	B
18	PMA	Return air mixing plenum	HC/VC/VD	B
19	PD	Straight plenum (return or delivery)	HC/VC/VD	B
20	PS	Plenum with spigot (return or delivery)	HC/VC/VD	B
21	PRA	Return air regulation plenum	HC/VC/VD	B
22	PB3-PB4	Plenum with 3 or 4 row post-heating coil	HC/VC/VD	B
23	PEH	Plenum with electric heaters	HC/VC/VD	
24	GM2	Dual adjustment delivery grille	HC/VC/VD	B
25	GR	Return grille	HC/VC/VD	B
26	GRD	Decorative return grille	HC/VC/VD	A
27	PGM2	Dual adjustment delivery grille	HC/VC/VD	A
28	PGR	Plenum with return grille	HC	A
29	COIB	Insulation for plenum	HC/VC/VD	B
30	SL	Duct silencer	HC/VC/VD	B
		FILTRATION		
31	FS-FA1...7	Low and medium efficiency filters	HC/VC/VD	A
32	FRAF6-7-8	Return flange with high efficiency pocket filter	HC	B
		PAINTING		
33	COL	Unit external metal plate painting	HC/VC/VD	A
34	COLP	Plenum Painting	HC/VC/VD	A

HC/VC/VD: HC = accessory available for horizontal version HC; VC = available for vertical version VC; VD = accessory available for vertical version VD

A/K/B: A = accessory supplied mounted on the base unit; K = accessory supplied in a kit i.e. not assembled; B = accessory supplied assembled, but not mounted on the base unit

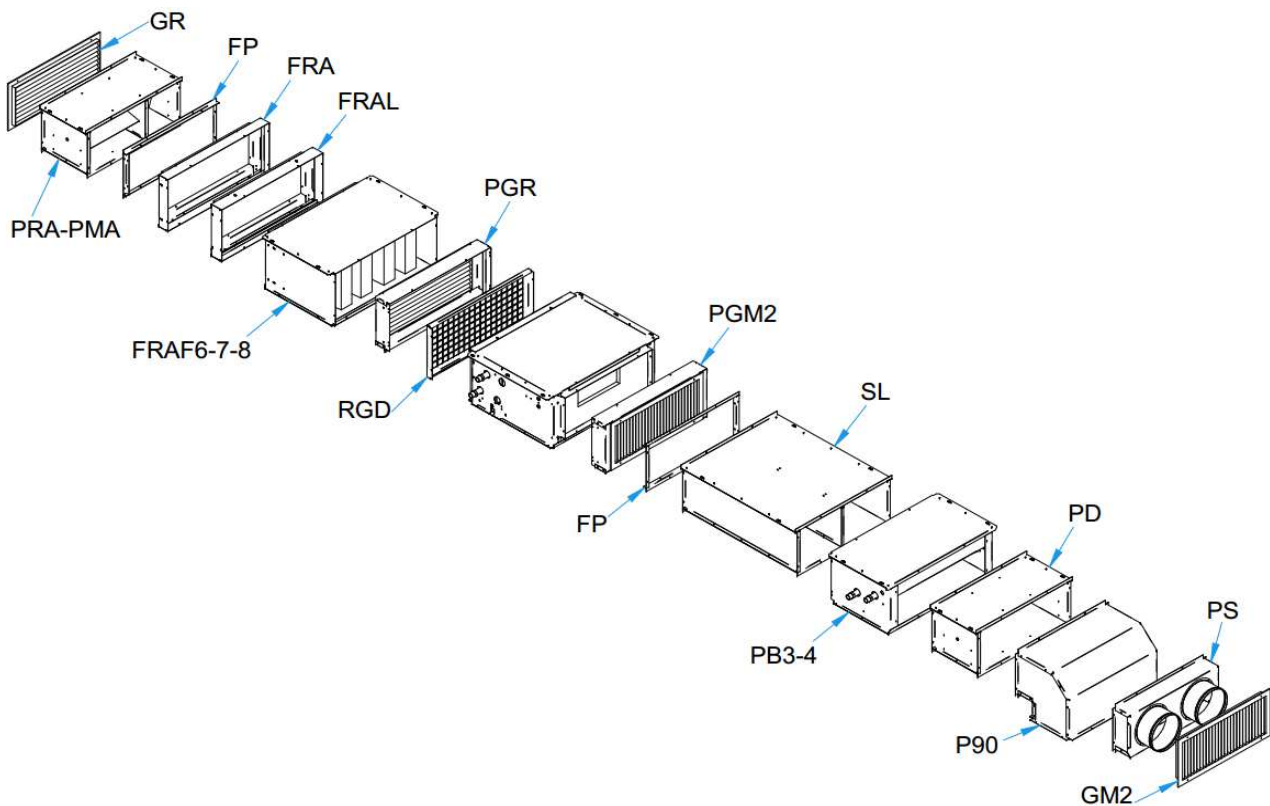

As shown in the table below, the accessories of the "G1" group can be connected directly to the machine frame; the accessories of the "G2" group need the FP accessory (if connected to the delivery end) or FRA + FP (if connected to the return end) in order to be connected to the machine frame. In addition, the accessories of the "G2" group can be connected in series with each other.

	Group	DELIVERY	RETURN
FP	G1	X	X (after FRA)
FRAB / FLAL / FRAV	G1	-	X
P90	G2	X (after FP)	X (after FRA+FP)
PMA	G2	-	X (after FRA+FP)
PD	G2	X (after FP)	X (after FRA+FP)
PS	G2	X (after FP)	X (after FRA+FP)
PRA	G2	-	X (after FRA+FP)
PB3 - PB4	G1	X	-
PEH	G2	X (after FP)	-
GM2	-	X (after ducting)	-
GR	-	-	X (after ducting)
GRD	G1	-	X
GMD	G1	X	-
PGM2	G1	X	-
PGR	G1	-	X
FRAF6 - 7 - 8	G1	-	X
SL	G2	X (after FP+PD/P90)	X (after FRA+FP)

Unless otherwise specified, the same accessories are compatible with both single-panel (SP) and double-panel (DP) units and therefore, in this case, the ordering code for the accessory is the same. All plenums, unless otherwise specified, have a structure similar to single panel units, i.e. a metal plate possibly insulated internally (optional). In the event that there are two separate accessories for single and double panel units, two separate codes are specified.

9.1-Auxiliary coil with 1 or 2 rows (B1-B2)

The auxiliary coil (B1-B2) is used for heating purposes in 4-pipe systems. For correct management of heating and cooling, in 4-pipe systems it is necessary to provide motorized valves on both coils (main and auxiliary) ensuring that only one of the two coils is active.

This accessory is not compatible with the electrical heater accessory (EH) and with the 6-row main coils.

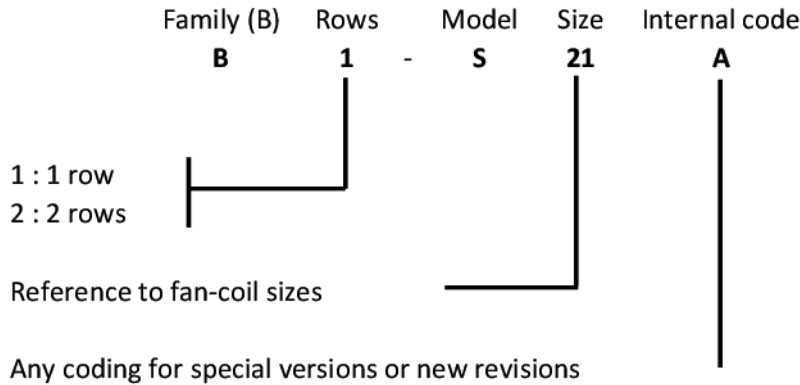

9.2-Valves (V)

Servo-controlled valves should be used to prevent the formation of condensate on the surface of the unit when the fan has stopped.

The valves are supplied disassembled in kit form to eliminate the risk of damage during transport and installation.

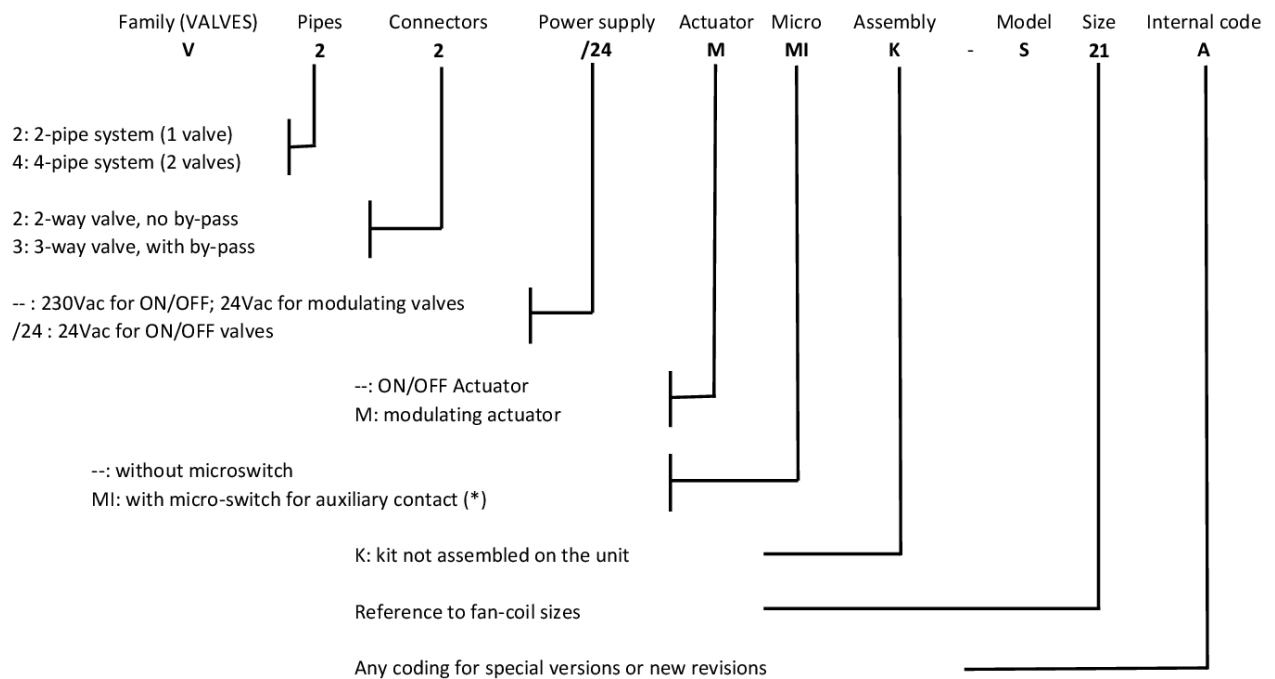

(*) available only for size 21, 31, 38 ON/OFF valves

VALVES FOR MAIN COIL					
	21	31	38	41	81
GENERAL CHARACTERISTICS					
Valve size	3/4"	1"	1"	1"	1"
Connection fitting size	3/4"	3/4"	3/4"	1"	1"
Kvs (2-way valve)	2.5	4.5	4.5	6.5	9.6
Kvs (3-way valve, direct flow)	2.5	4.5	4.5	6.5	9.6
Kvs (3-way valve, by-pass)	1.6	3.1	3.1	3.3	8.6
Max differential pressure	1.0bar	0.7bar	0.7bar	1.5bar	1.4bar
Nominal pressure	16bar				
Water temperature	4 – 110°C				
ACTUATOR ON/OFF					
Power supply	230V-50Hz (24V-50Hz on request)				
Number of wires	2 wires		2 wires		3 wires
Absorbed power	2.5W		18W		4.0VA - 2.0W
Stroke time	180s		240s		120s
Characteristic (valve+actuator)	N.C. (Normally Closed)				
Protection	IP44		IP20		IP54
MODULATING ACTUATOR					
Power supply	24V-50Hz				
Absorbed power	2.5VA - 1.5W		18W		8.7VA – 4.9W
Stroke time	8s		240s		240s
Control signal	0-10V				
Control signal impedance	100k				
Protection	IP43		IP42		IP54

VALVES FOR AUXILIARY COIL					
	21	31	38	41	81
GENERAL CHARACTERISTICS					
Valve size	3/4"	3/4"	3/4"	1"	1"
Connection fitting size	3/4"	3/4"	3/4"	1"	1"
Kvs (2-way valve)	2.5	2.5	2.5	6.5	6.5
Kvs (3-way valve, direct flow)	2.5	2.5	2.5	6.5	6.5
Kvs (3-way valve, by-pass)	1.6	1.6	1.6	3.3	3.3
Max differential pressure	1.0bar	1.0bar	1.0bar	1.5bar	1.5bar
Nominal pressure	16bar				
Water temperature	4 – 110°C				
ACTUATOR ON/OFF					
Power supply	230V-50Hz (24V-50Hz on request)				
Number of wires	2 wires		2 wires		
Absorbed power	2.5W		18W		
Stroke time	180s		240s		
Characteristic (valve+actuator)	N.C. (Normally Closed)				
Protection	IP44		IP20		
MODULATING ACTUATOR					
Power supply	24V-50Hz				
Absorbed power	2.5VA - 1.5W		18W		
Stroke time	8s		240s		
Control signal	0-10V				
Control signal impedance	100k				
Protection	IP43		IP42		

SOFFIO



Straight flow pressure drop graph

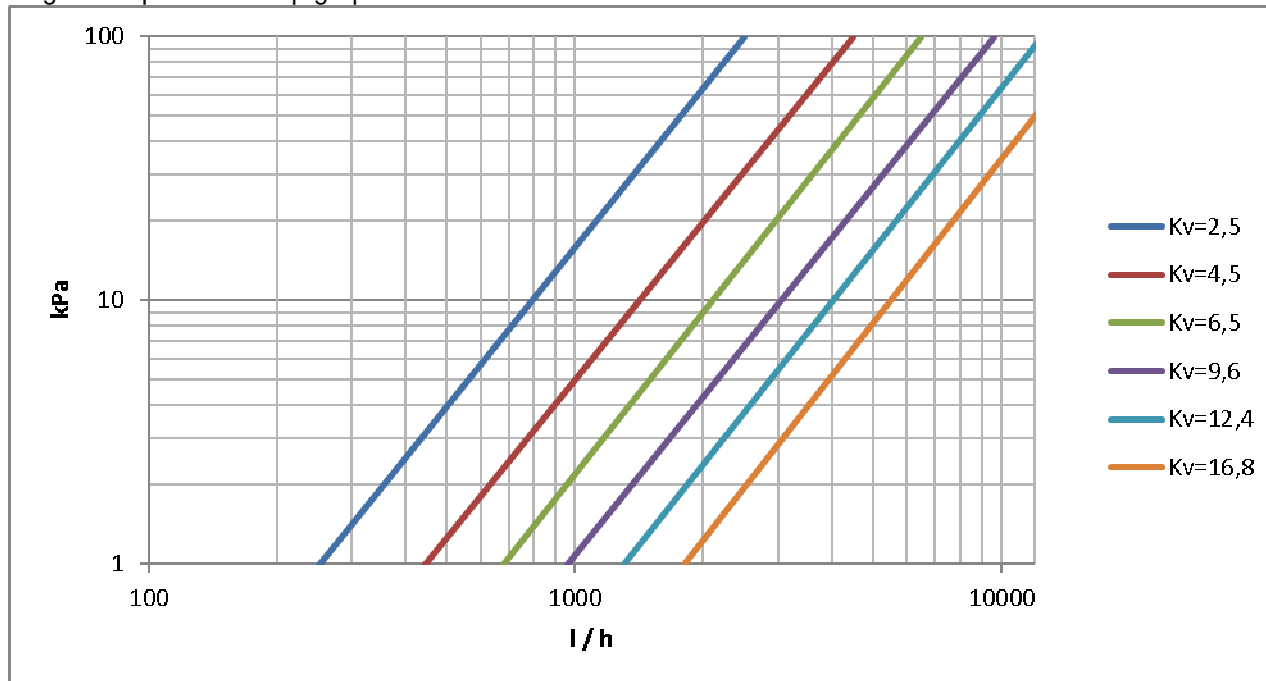

By-pass pressure drop graph

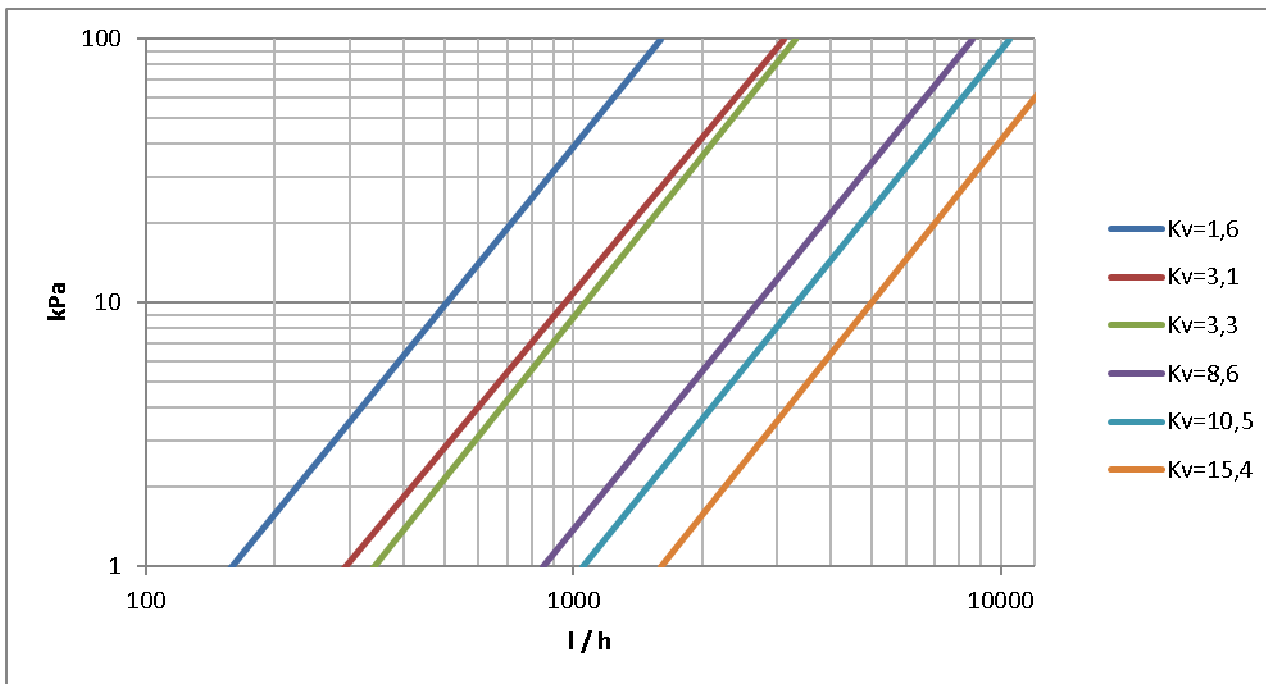

Dynamic balancing valves (VBD) are also available as accessories; for information please refer to the specific technical manual

9.3-Auxiliary condensate collection tray (VCS)

The auxiliary condensate collection tray is made of galvanized and painted sheet metal. It is fixed to the external side of the unit, below the valves.

It allows to collect any condensate dripping from the valves and connection fittings to the unit. This condensate is conveyed through a main pipe to the main tank inside the unit. Its dimensions are suitable for covering the footprint not just of the valves (V), but also of any other accessories connected in series to the valves (BLV calibration and balancing valves, SOV ball valves etc.)

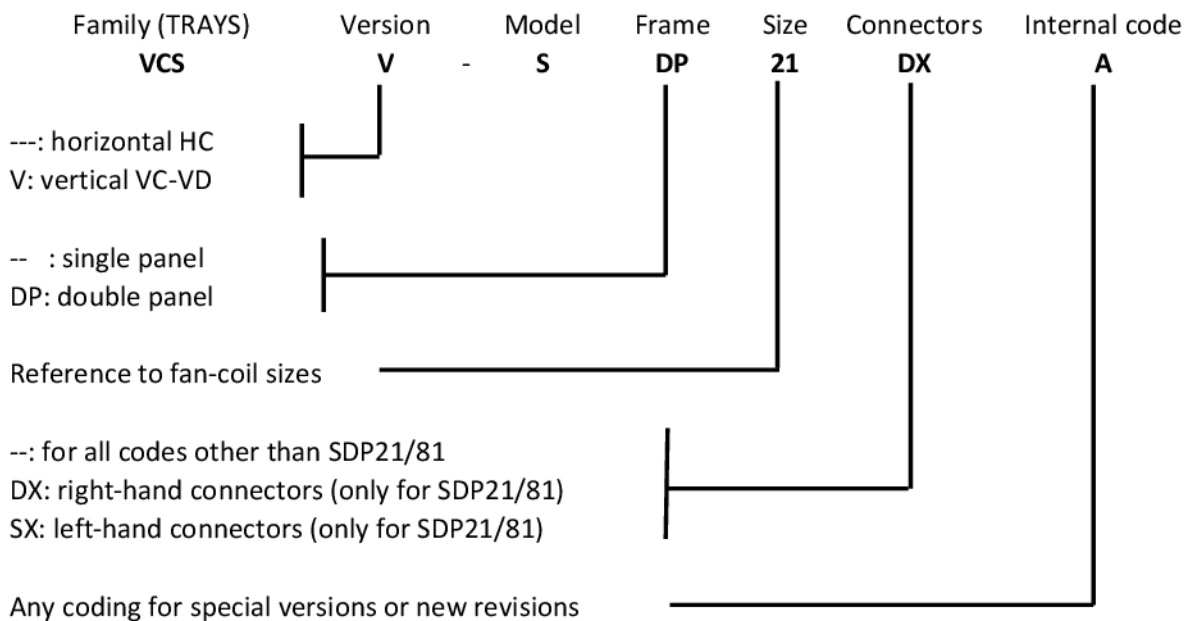

	DIMENSIONS (mm)				
	21	31	38	41	81
A	500	500	500	500	500

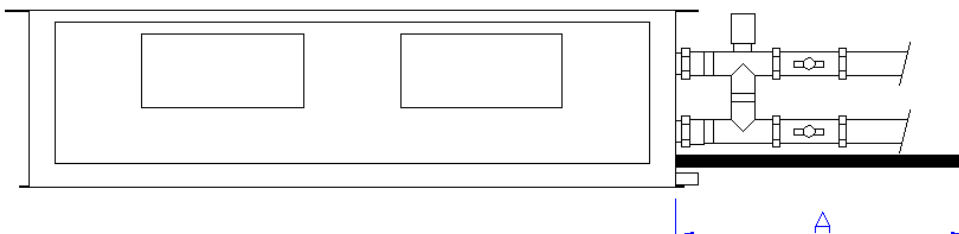

9.4-Condensate drain pump (PSC)

The condensate drain pump is supplied as an unassembled kit to avoid damage during transport and installation.

Family (PUMPS)	Model	Size	Internal code
PSC	S	21	A

Reference to fan-coil sizes

Any coding for special versions or new revisions

	21-38-81
Maximum water flow rate	30 l/h
Maximum suction height (A)	4m
Maximum drain height (B)	13m (8 l/h)
Sound pressure at 1 m	34dB(A)
Power supply	230V – 50/60Hz
Absorption	21W
Alarm microswitch	Resistive NC 8A 250V
Circuit breaker	90°C (automatic reset)
Protection	IP20

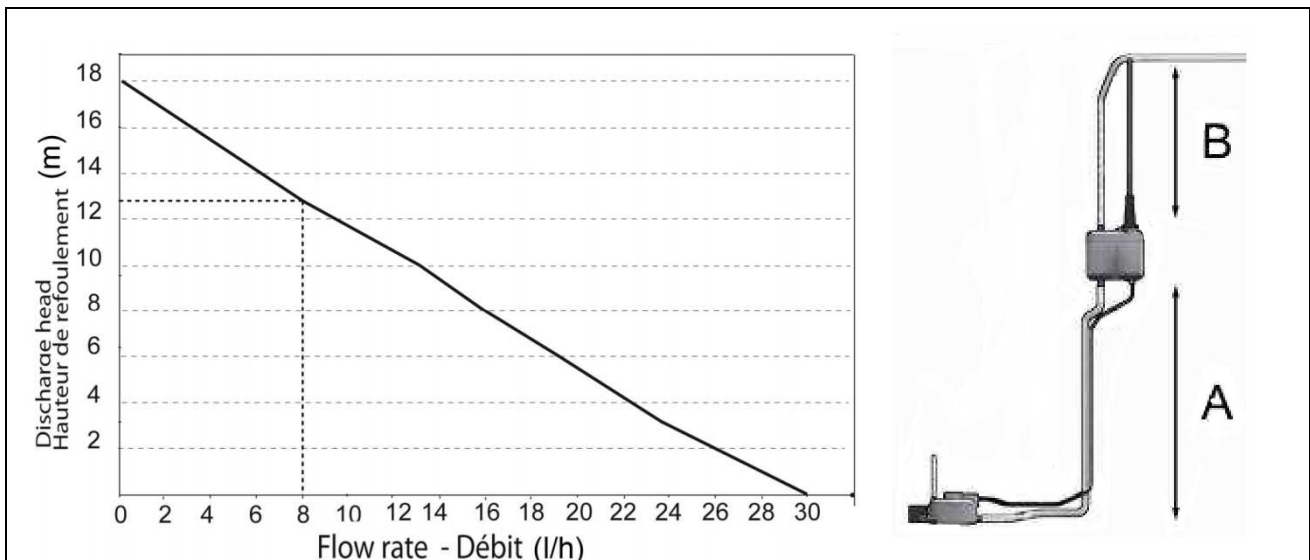

9.5-Static balancing and calibration valve (BLV)



The static balancing valve is supplied as an unassembled kit. It allows the water flow to be adjusted to prevent cases where, in an unbalanced system, the fan units closest to the central heating unit receive an excessive flow of water, while the units furthest away will not receive enough: the temperature differences that can be detected in different areas, in addition to creating discomfort, will increase consumption. The installation of calibration and balancing valves on each unit, once the calibration operations have been completed, guarantee correct flow distribution with an immediate beneficial impact in terms of comfort and lower consumption, in addition to enhancing the regulation system efficiency.

CALIBRATION VALVES FOR MAIN COIL					
	21	31	38	41	81
Valve size	3/4"	3/4"	3/4"	1"	1"
Connection fitting size	3/4"	3/4"	3/4"	1"	1"
Kvs	2.15	5.7	5.7	8.7	8.7
Max pressure	10 bar	20 bar	20 bar	20 bar	20 bar

CALIBRATION VALVES FOR AUXILIARY COIL					
	21	31	38	41	81
Valve size	3/4"	3/4"	3/4"	1"	1"
Connection fitting size	3/4"	3/4"	3/4"	1"	1"
Kvs	2.15	2.15	2.15	8.7	8.7
Max pressure	10 bar	10 bar	10 bar	20 bar	20 bar

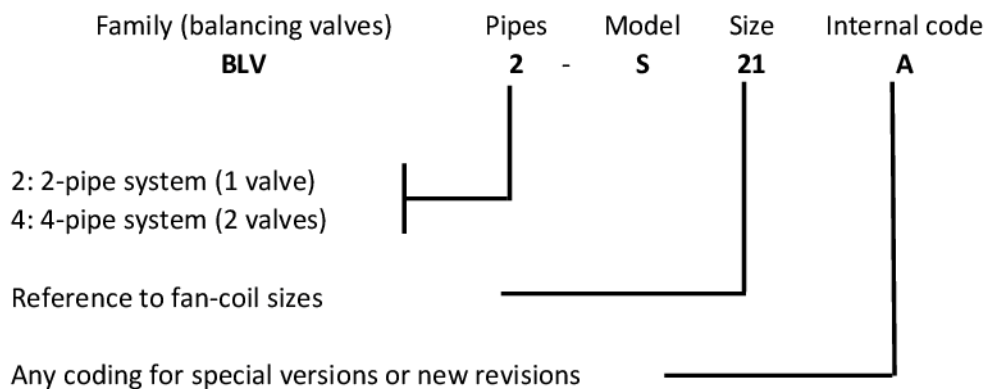

9.6-Shut-off ball valve (SOV)



The shut-off ball valve is supplied as an unassembled kit. Its installation allows to bypass the unit in the hydraulic system to carry out maintenance on the coil or valve. These being "full bore" valves, the pressure drop is very limited.

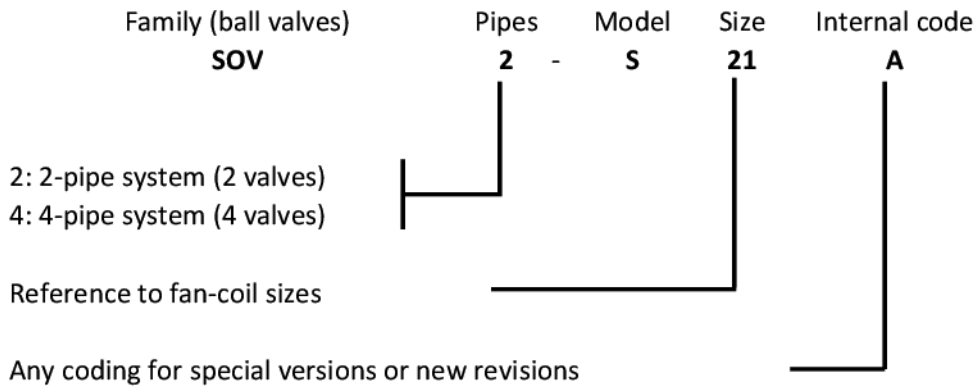

BALL VALVES FOR MAIN COIL					
	21	31	38	41	81
Valve size	3/4"	3/4"	3/4"	1"	1"
Connection fitting size	3/4"	3/4"	3/4"	1"	1"
Kvs	2.15	5.7	5.7	8.7	8.7
Max pressure	40 bar	40 bar	40 bar	40 bar	40 bar

BALL VALVES FOR AUXILIARY COIL					
	21	31	38	41	81
Valve size	3/4"	3/4"	3/4"	1"	1"
Connection fitting size	3/4"	3/4"	3/4"	1"	1"
Kvs	2.15	2.15	5.7	8.7	8.7
Max pressure	40 bar	40 bar	40 bar	40 bar	40 bar

9.7-Flexible hoses (FLEX)



The flexible hoses are supplied as kits (disassembled components). Their use makes the hydraulic connection of the unit easier

External metal braid material	AISI304 stainless steel
Internal material	EPDM
Fittings and elbows material	Brass, chrome-plated brass, copper
Maximum working pressure	See table, according to the diameter
Water temperature	5 - 85°C

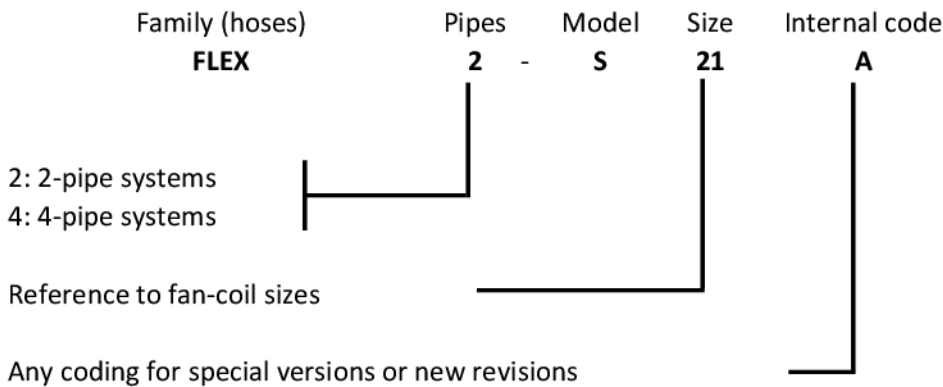

FLEXIBLE HOSES FOR MAIN COIL					
	21	31	38	41	81
Pipe size	DN20	DN20	DN20	DN25	DN25
Length	200mm	200mm	200mm	200mm	200mm
Connection fitting size	3/4"	3/4"	3/4"	1"	1"
Max pressure	10 bar	10 bar	10 bar	10 bar	10 bar

FLEXIBLE HOSES FOR AUXILIARY COIL					
	21	31	38	41	81
Pipe size	DN20	DN20	DN20	DN25	DN25
Length	200mm	200mm	200mm	200mm	200mm
Connection fitting size	3/4"	3/4"	3/4"	1"	1"
Max pressure	10 bar	10 bar	10 bar	10 bar	10 bar

9.8-Transformer for modulating valves (TR24)

The TR24 accessory is a 230Vac - 24Vac 20VA transformer needed to power the modulating valves. In the event that there are two modulating valves for the same unit (4-pipe system), only one transformer is sufficient to supply both valves.

TR24 is available in one size, suitable for all unit sizes.

9.9-Power relay board (ETBN-2.5A and ETBN-6A)

The power relay board (ETBN-2.5A o ETBN-6A) is necessary when a unit equipped with a single (three speeds) AC motor must be controlled with a thermostat that is unable to carry the maximum current absorbed by the motor. It is also possible to control more than one unit with (three speeds) AC motor through a single control, providing all the units with a board. For more information on this accessory, please refer to its specific technical manual.

The ETBN-2.5A board can be used for the SOFFIO sizes 21 to 41.
The ETBN-6A board can be used for the SOFFIO 81 size

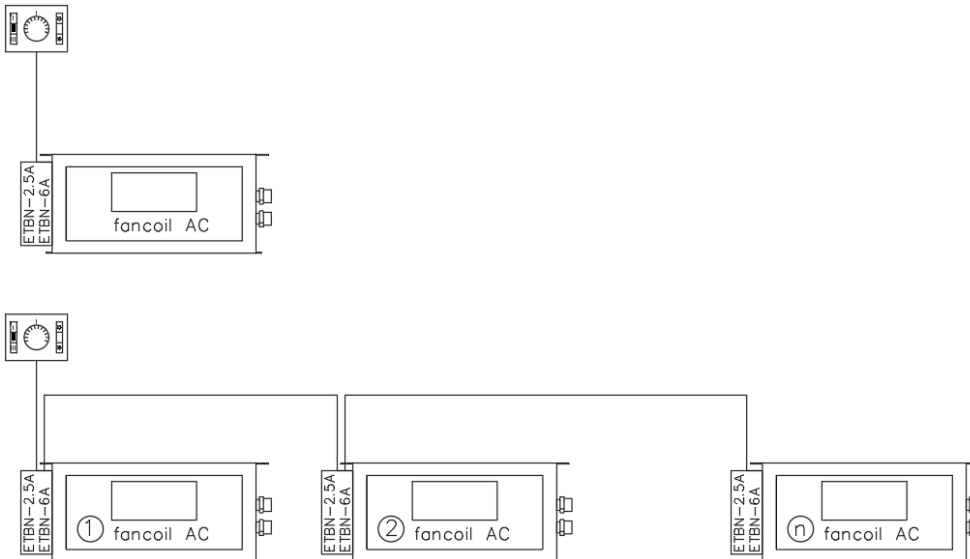

9.10-Three-speed EC motor control board (SC3)

The SC3 board allows an EC motor (with 0/10V signal) to be controlled through a common three speed control for AC motors. It is possible to control several (up to 20) units equipped with SC3 through a single control. For more information on this accessory, please refer to its specific technical manual.
The SC3 board is available in one size, suitable for all unit sizes.

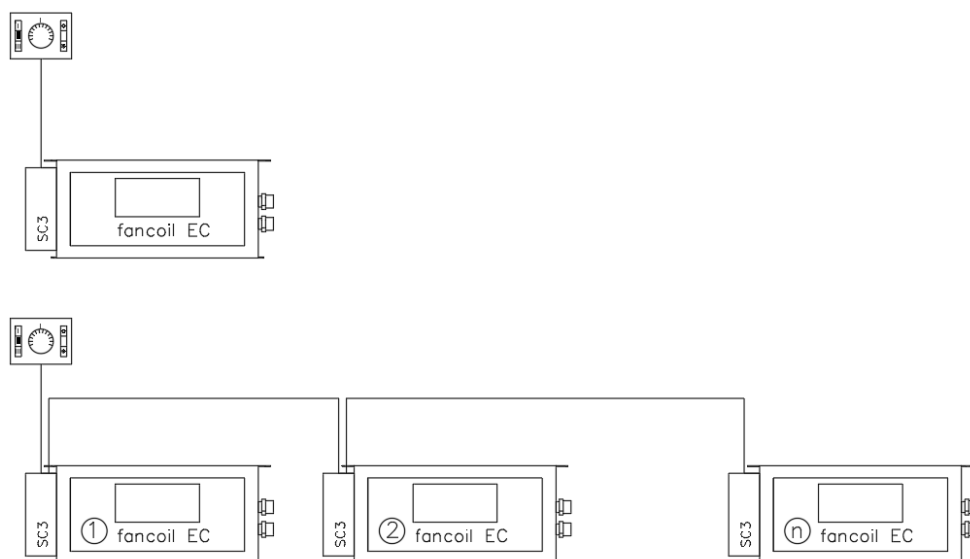

9.11-Electrical heater (EH) and relay (EHR)

The electric heaters are made of aluminium and are equipped with a safety thermostat against overheating. They are housed inside the machine between the coil and the fan unit.

This accessory is not compatible with the auxiliary coil accessories and with the 6-row coil.

To control the heaters, it is recommended to use the EHR (power relay) accessory.

We recommend not to use the electric heater if the main coil is fed chilled water or if there is humidity or condensation on the coil or heater. Before turning on the electric heater, make sure that the cooling system is turned off and that the valves of the main coil are closed.

For correct dissipation of the heat generated by the electric heaters, it is recommended to never use the minimum fan speed and to use instead the maximum and medium speed settings (to be chosen also in relation to the pressure drops in the ducting). After the heaters are turned off, it is recommended to leave the fan on for a few minutes (at least two minutes) to allow the electric heaters to cool.

Incorrect management of ventilation and some occasional events (e.g. sudden fan unit stop due to a blackout) could overheat and damage the motor. Therefore, in the event that very frequent activation of the electric heaters is expected, it is safer to use the electric heaters in a delivery plenum, externally to the unit.

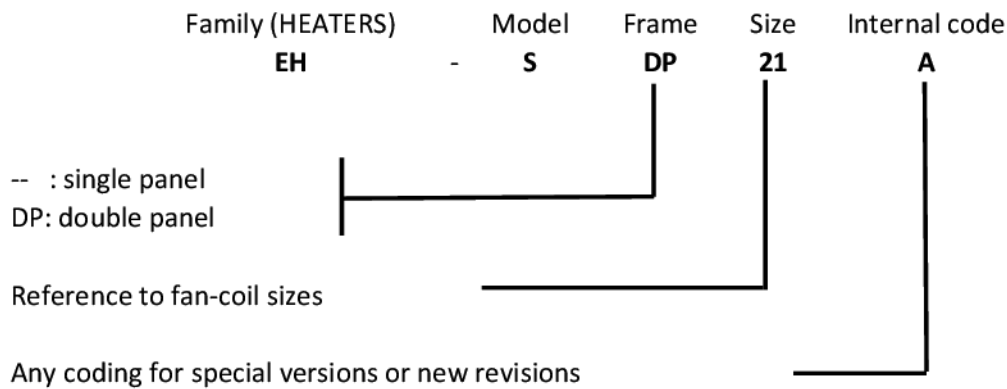

	21	31-38	41-81
Power	2.0 kW	4.0 kW	6.0 kW
Power supply	230V-50Hz single-phase		
N. of stages / N. of elements	1 / 1	1 / 2	1 / 2
Power relays to be used	EHR-20A		

	EHR-20A
Maximum contact current (resistive load)	20 A
Coil power supply	230V-50Hz single-phase
No. of contacts	4

9.12-Fluid-tight electrical panel (IPB)

This accessory allows the terminal block and electrical devices inside the electrical panel (fixed to the side of the unit) to be better protected from water spray and splashes. It consists of a plastic box, with special seals and cable glands.

9.13-Flat flange (FP)

The flat flange is required to connect the accessories of the “G2” group (see the table at the beginning of the paragraph) to the delivery flange or to the return flange accessory (FRA).

Family (flat flange)	Model	Size	Internal code
FP	- S	21	A
Reference to fan-coil sizes			
Any coding for special versions or new revisions			

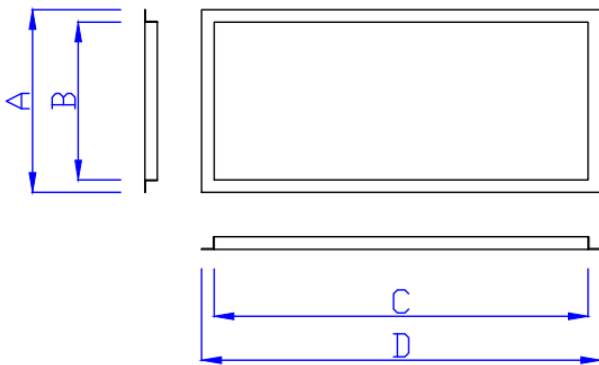

	DIMENSIONS (mm)				
	21	31	38	41	81
A	278	278	278	338	338
B	240	240	240	300	300
C	570	1010	1010	1560	1560
D	608	1048	1048	1598	1598

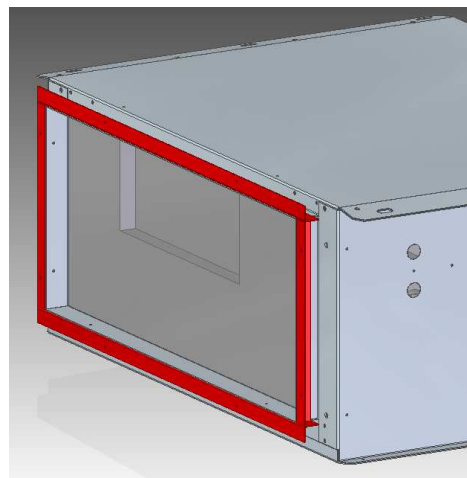
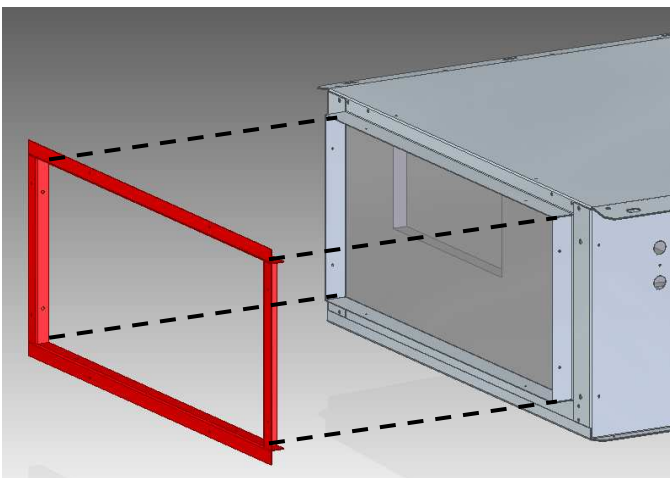

9.14-Return flange (FRAB)

The return flange is needed to channel the return flow. The 6-15-20-25mm thick filter can be housed internally, with extraction only from the bottom.

For double panel units (DP) the filter is already housed inside the unit, therefore the accessory only includes the return flange.

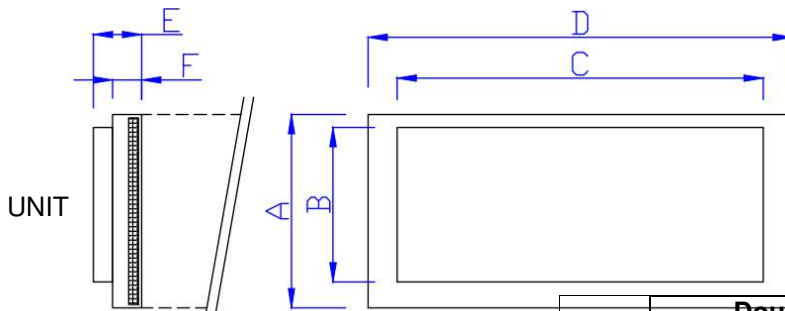
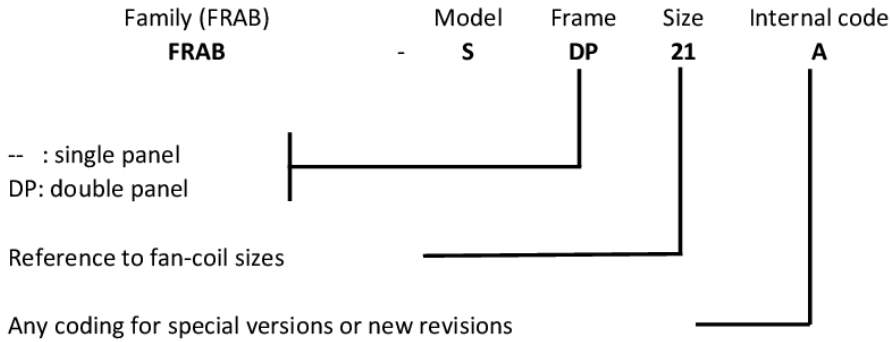

	Single panel unit (SP)				
	DIMENSIONS (mm)				
	21	31	38	41	81
A	300	300	300	375	375
B	240	240	240	300	300
C	570	1010	1010	1560	1560
D	660	1100	1100	1650	1650
E	75	75	75	75	75
F	45	45	45	45	45

	Double panel unit (DP)				
	DIMENSIONS (mm)				
	21	31	38	41	81
A	335	335	335	410	410
B	240	240	240	300	300
C	570	1010	1010	1560	1560
D	730	1170	1170	1720	1720
E	45	45	45	45	45
F	20	20	20	20	20

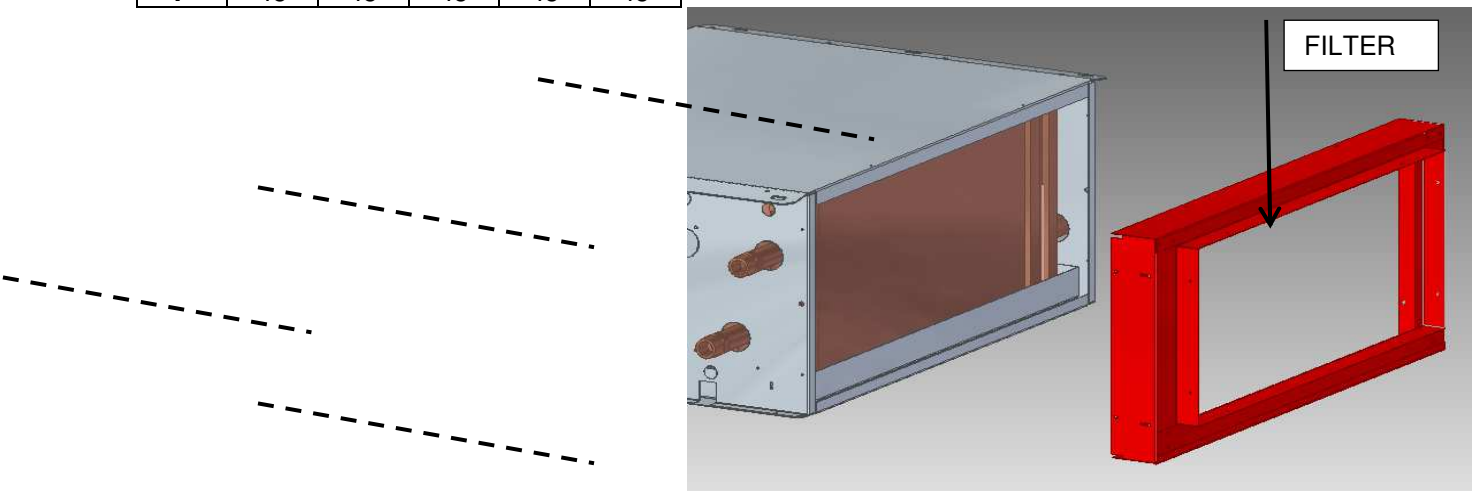

9.15-Return flange (FRAL)

The return flange is needed to channel the return flow. The 6-15-20-25mm thick filter can be housed internally, with extraction only from the side.

This accessory is not compatible with double panel units (DP) because the filter is already housed inside the unit with extraction only from the bottom.

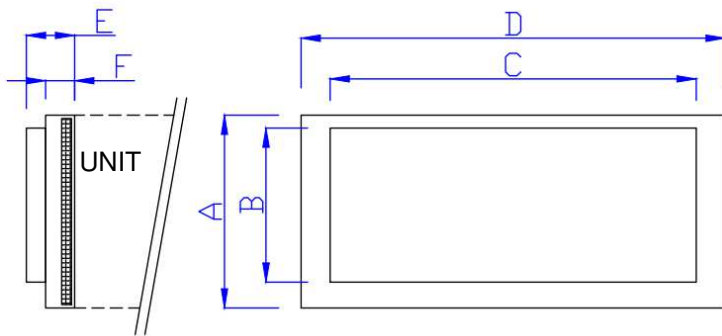
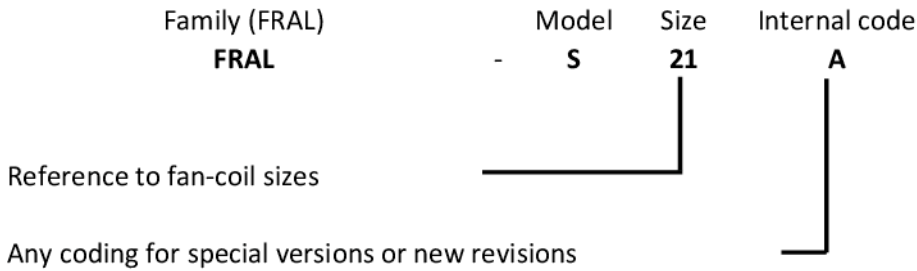

	DIMENSIONS (mm)				
	21	31	38	41	81
A	300	300	300	375	375
B	240	240	240	300	300
C	570	1010	1010	1560	1560
D	660	1100	1100	1650	1650
E	85	85	85	85	85
F	55	55	55	55	55

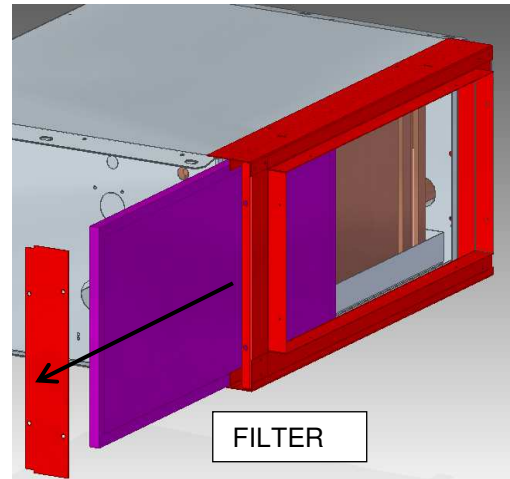
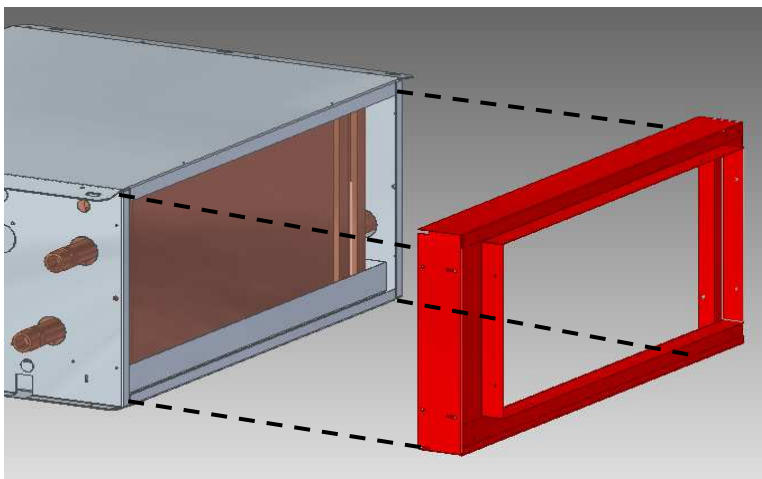

9.16 -Return flange for vertical version (FRAV)

The return flange is needed to channel the return flow. The 6-15-20-25mm thick filter can be housed internally, with extraction only from the front.

Family (FRAL) Version Model Size Internal code
FRAV **D** - **S** **21** **A**

-- : vertical VC
D: vertical VD

Reference to fan-coil sizes

Any coding for special versions or new revisions

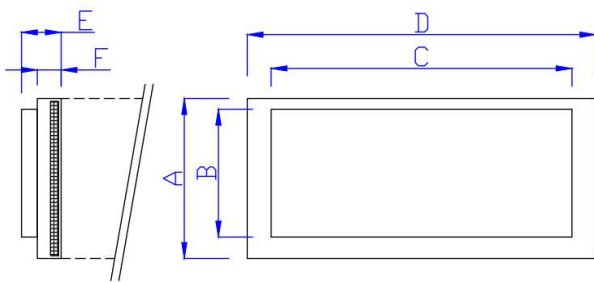

	DIMENSIONS (mm)				
	21	31	38	41	81
A (for VC)	320	320	320	375	375
A (for VD)	300	300	300	375	375
B	240	240	240	300	300
C	570	1010	1010	1560	1560
D	660	1100	1100	1650	1650
E	75	75	75	75	75
F	45	45	45	45	45

FRAV for VC version

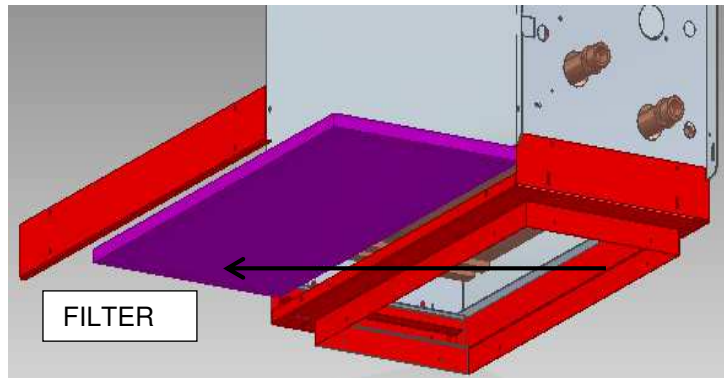
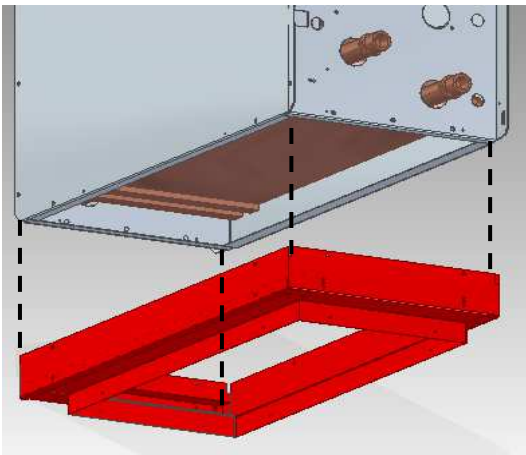

FRAV for VD version

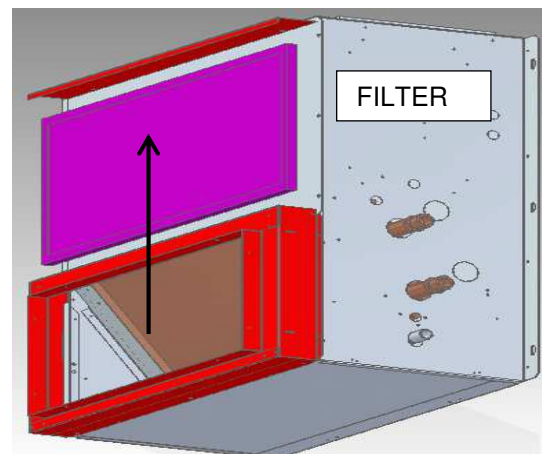
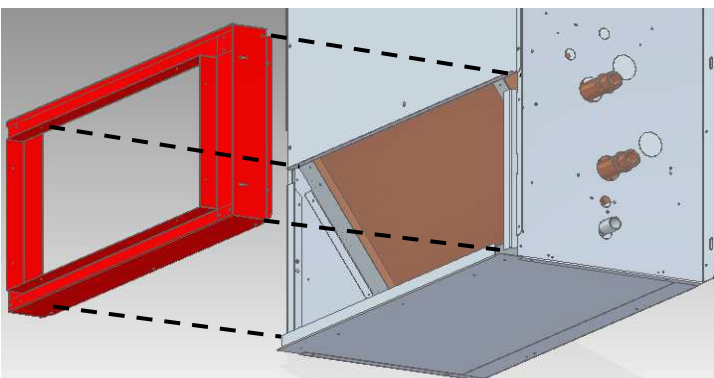

9.17-90° Plenum (P90)

The 90° plenum can be installed both on the delivery and on the return end.

Family (P90)

P90

Model

S

Size

21

Internal code

A

Reference to fan-coil sizes

Any coding for special versions or new revisions

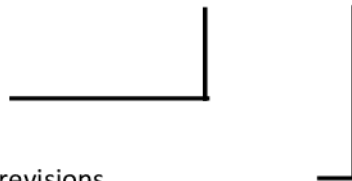

	DIMENSIONS (mm)				
	21	31	38	41	81
A	278	278	278	338	338
B	240	240	240	300	300
C	570	1010	1010	1560	1560
D	608	1048	1048	1598	1598
E	335	335	335	395	395
F	335	335	335	395	395

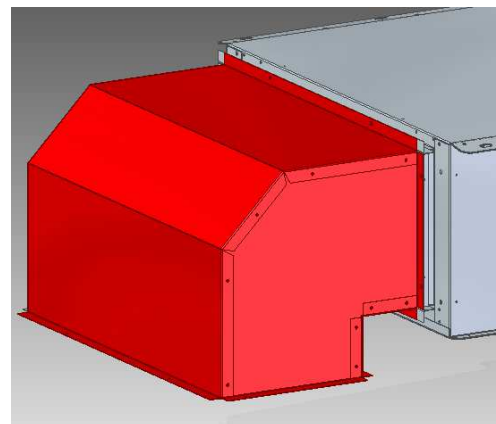
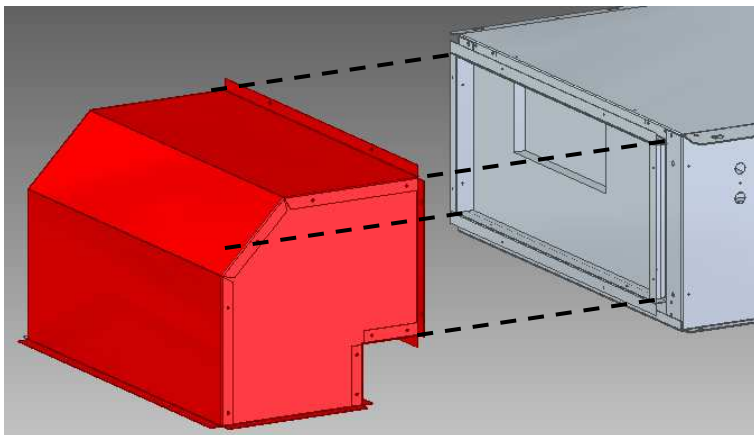
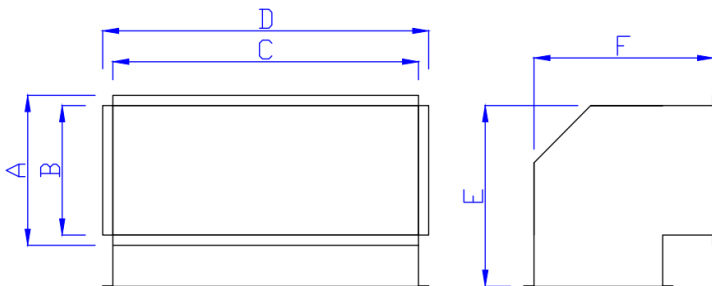

9.18-Return air mixing plenum (PMA)

The air mixing plenum is installed in the return section and allows for manual adjustment of the recirculation and fresh air flow rate (approximately 67-33%). On request, it is possible to add an electric servo control. The fresh air must be previously treated through a heat recovery unit or similar units. Direct intake of outdoor air is not allowed.

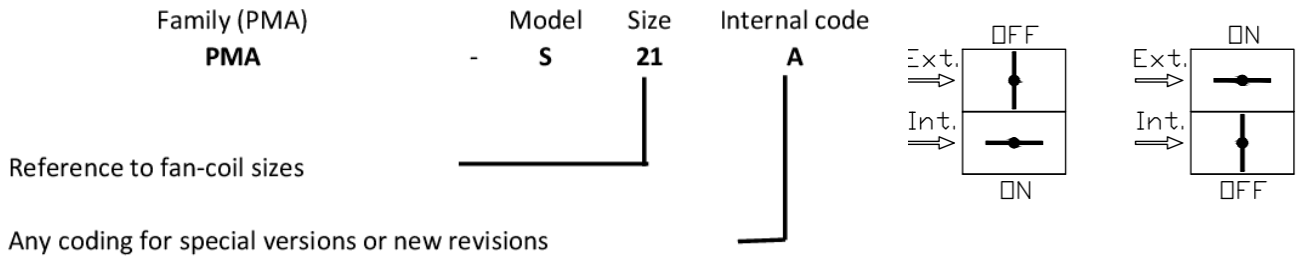

	DIMENSIONS (mm)				
	21	31	38	41	81
A	278	278	278	338	338
B	240	240	240	300	300
C	570	1010	1010	1560	1560
D	608	1148	1148	1598	1598
E	170	315	315	500	500
F	360	655	655	1020	1020
G	630	1070	1070	1620	1620
H	300	300	300	350	350
I	40	40	40	40	40

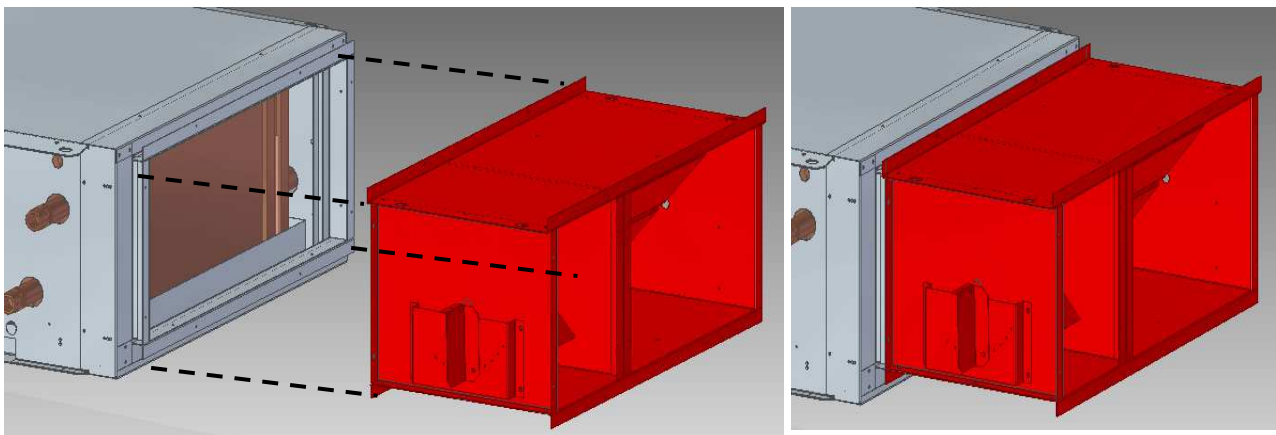

9.19-Straight plenum (PD)

The straight plenum can be installed both on the delivery and on the return end.

Family (PD) Model Size Internal code
PD - **S** **21** **A**

Reference to fan-coil sizes

Any coding for special versions or new revisions

	DIMENSIONS (mm)					
	21	38	81	91	101	121
A	278	278	338	458	458	608
B	240	240	300	400	400	550
C	570	1010	1560	1600	1850	2000
D	608	1148	1598	1658	1908	2058
E	630	1070	1620	1660	1910	2060
F	300	300	350	400	400	400

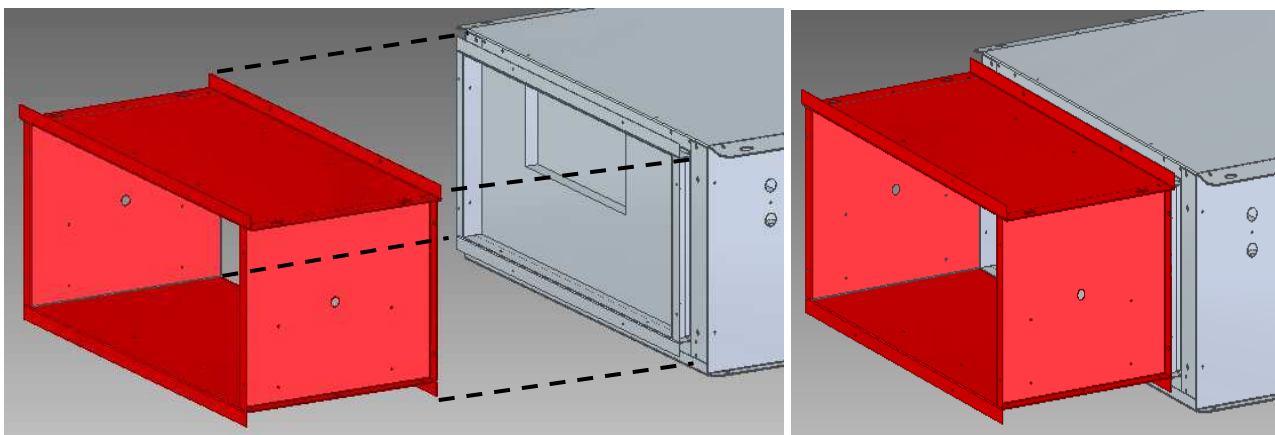
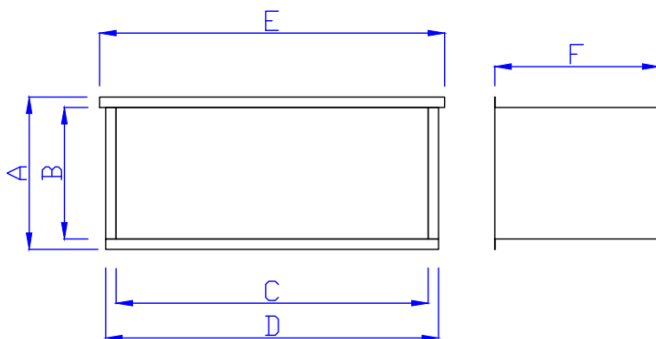

9.20-Plenum with spigot (PS)

The plenum with spigot can be installed both in the delivery and in the recovery section and is suitable for connecting circular ducting.

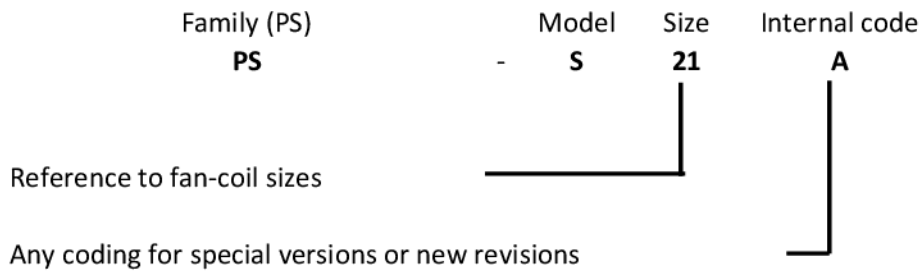

	DIMENSIONS (mm)				
	21	31	38	41	81
A	278	278	278	338	338
B	240	240	240	300	300
C	570	1010	1010	1560	1560
N.	2	3	3	4	4
D	200	200	200	250	250
E	608	1048	1048	1598	1598
F	100	100	100	100	100
G	200	200	200	200	200

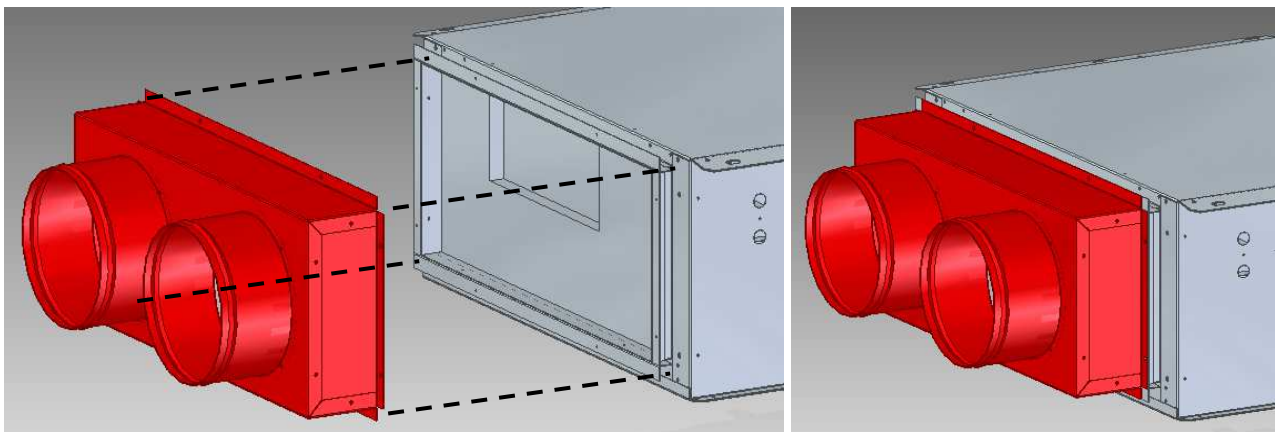
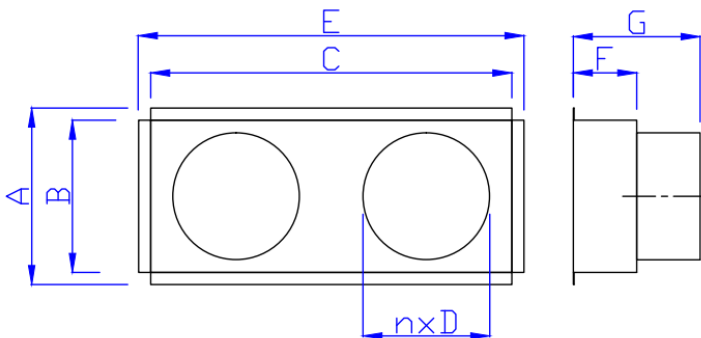

9.21-Air regulation plenum (PRA)

The air regulation plenum is installed in the intake section and allows for adjustment of the air flow, creating a pressure drop on intake. The damper is manually adjusted, an electric servomotor is available on request.

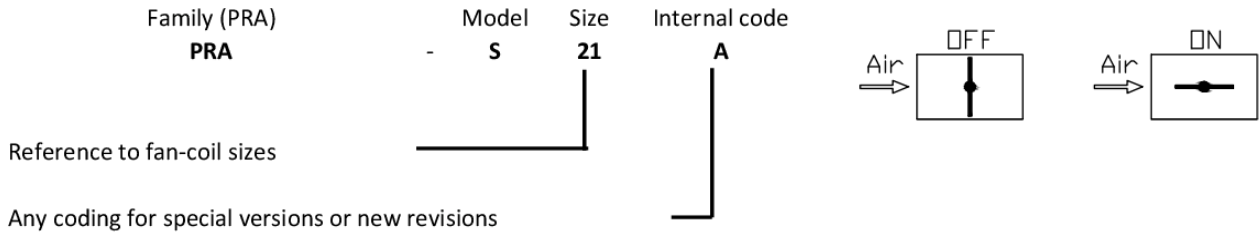

	DIMENSIONS (mm)				
	21	31	38	41	81
A	278	278	278	338	338
B	240	240	240	300	300
C	570	1010	1010	1560	1560
D	608	1148	1148	1598	1598
E	630	1070	1070	1620	1620
F	300	300	300	350	350

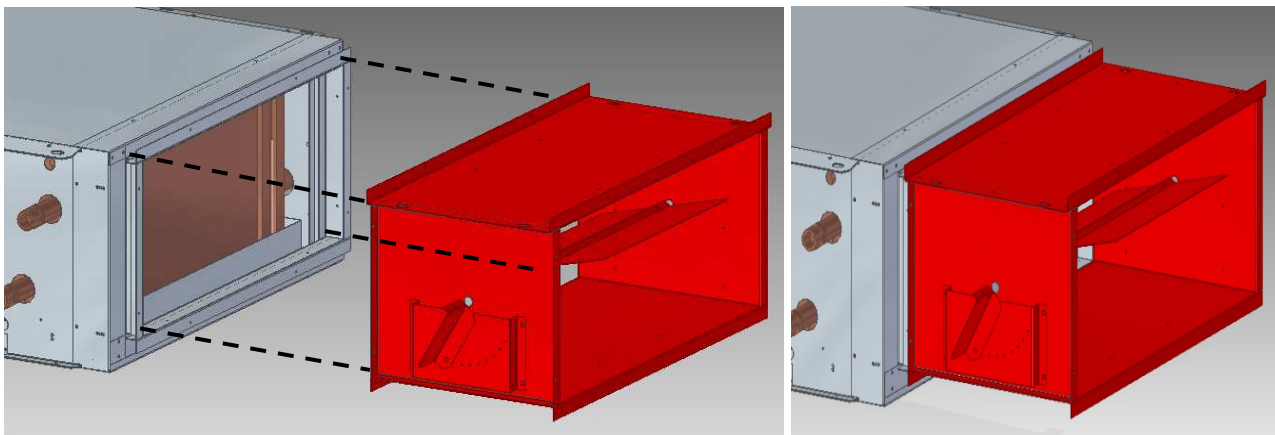
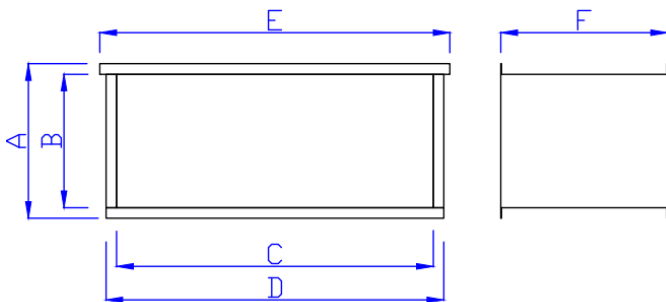

9.22-Plenum with 3 or 4 row post-heating coil (PB3 – PB4)

The post-heating plenum can be used in 4-pipe systems, when auxiliary coils with 1 or 2 rows are not sufficient. The pressure drop of the post-heating coil must be deducted from the available pressure head of the base machine.

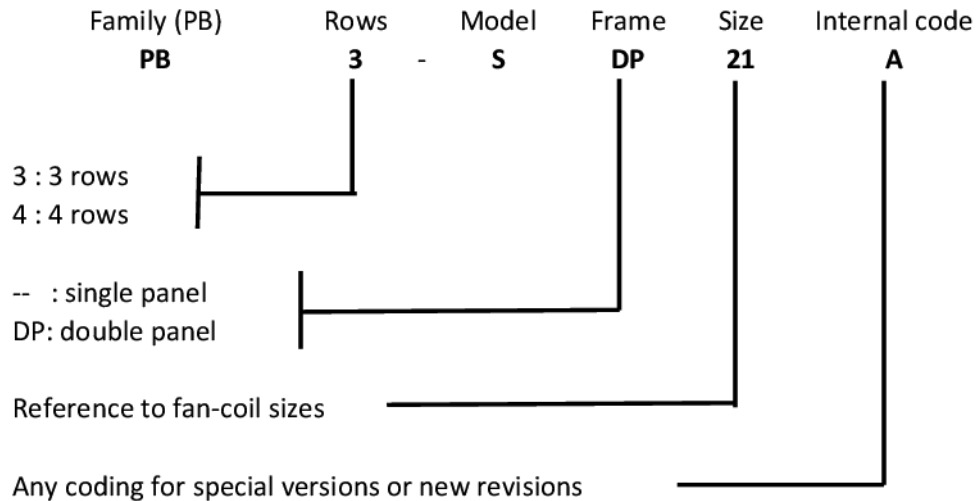

POST-HEATING COIL SOFFIO 21								
Air flow rate	m3/h	500	600	700	800	900	1000	1100
Pressure drop PB3	Pa	10	13	16	20	27	28	32
Pressure drop PB4	Pa	14	18	22	26	31	37	42

POST-HEATING COIL SOFFIO 31 - 38								
Air flow rate	m3/h	1000	1200	1400	1600	1800	2000	2200
Pressure drop PB3	Pa	12	15	19	23	27	32	37
Pressure drop PB4	Pa	15	20	25	30	36	42	48

POST-HEATING COIL SOFFIO 41 - 81								
Air flow rate	m3/h	2500	2750	3000	3250	3500	3750	4000
Pressure drop PB3	Pa	16	18	21	23	26	29	32
Pressure drop PB4	Pa	21	24	27	31	34	38	42

SOFFIO

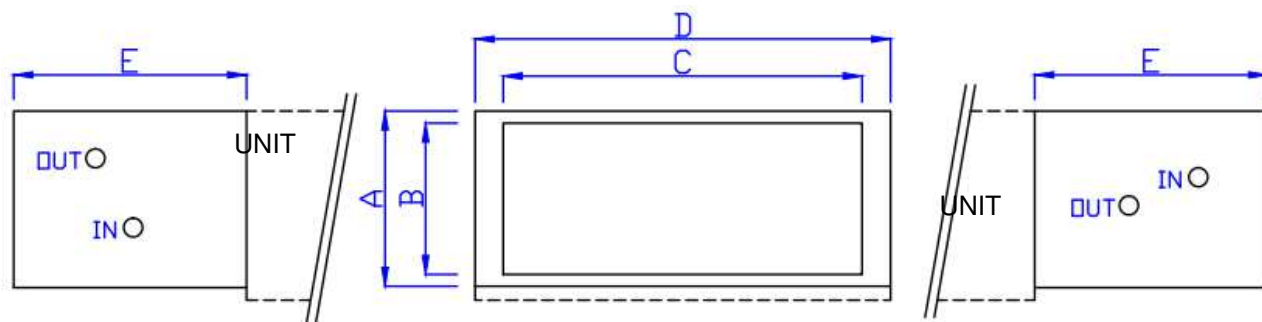

	DIMENSIONS (mm)				
	21	31	38	81	81
A	278	278	278	342	342
B	240	240	240	300	300
C	570	1010	1010	1560	1560
D	660	1100	1100	1650	1650
E	370	370	370	470	470

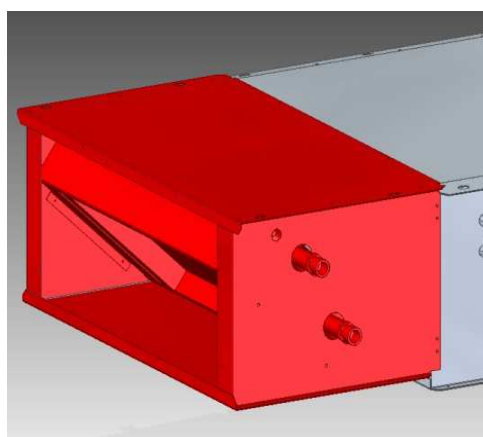
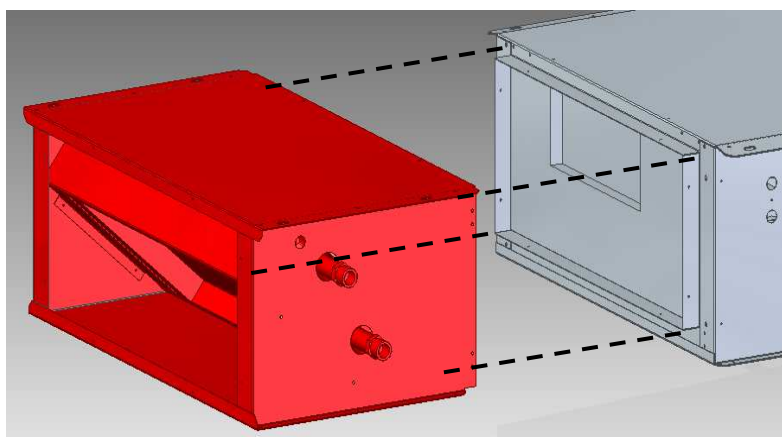

9.23-Plenum with electric heaters (PEH)

The plenum with electric heaters must be installed on the delivery end. It is made of galvanized sheet metal and includes an electrical box containing the relay or power contactor (EHR).

The electric heaters are made of aluminium and are equipped with a safety thermostat against overheating. For correct dissipation of the heat generated by the electric heaters, it is recommended to never use the minimum fan speed and to use instead the maximum and medium speed settings (to be chosen also in relation to the pressure drops in the ducting).

After the heaters are turned off, it is recommended to leave the fan on for a few minutes (at least two minutes) to allow the electric heaters to cool.

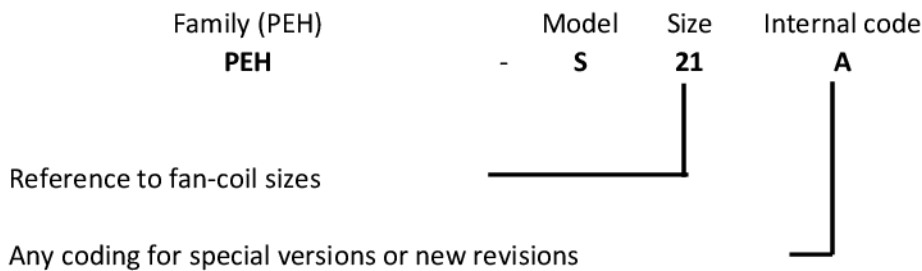

	21	31-38	41-81
Power	2.0 kW	4.0 kW	6.0 kW
Power supply	230V-50Hz single-phase		
N. of stages / N. of elements	1 / 1	1 / 2	1 / 2
Power relay (included)	EHR-20A		

	EHR-20A
Maximum contact current (resistive load)	20 A
Coil power supply	230V-50Hz single-phase
No. of contacts	4

SOFFIO

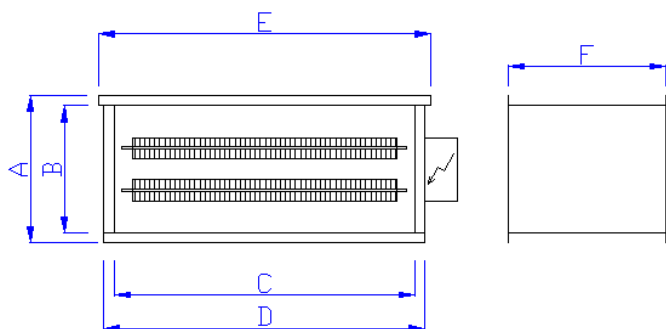

	DIMENSIONS (mm)				
	21	31	38	41	81
A	278	278	278	338	338
B	240	240	240	300	300
C	570	1010	1010	1560	1560
D	608	1148	1148	1598	1598
E	630	1070	1070	1620	1620
F	300	300	300	350	350

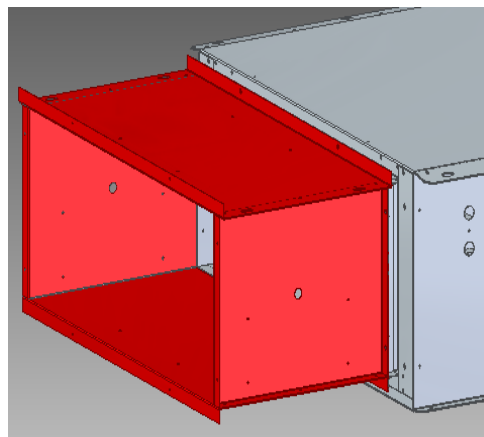
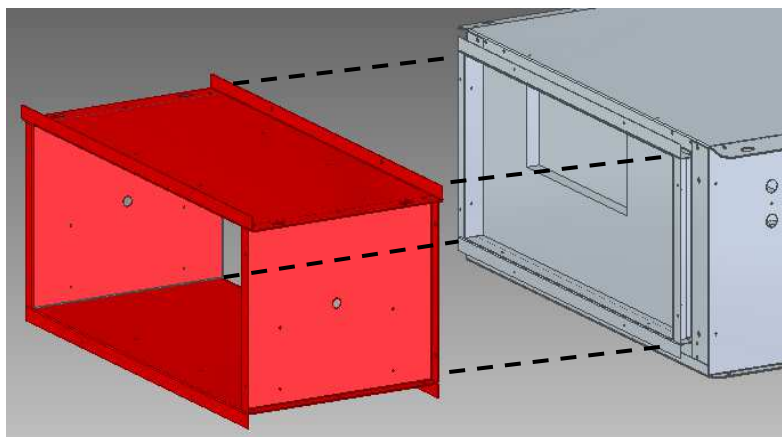

9.24-Delivery grille (GM2)

The delivery grille is made of anodised aluminium. It is equipped with two rows of fins, which allow for double adjustment of the air flow: vertically and horizontally.

The frame is provided with holes for fixing the grille by means of screws (not supplied) which must be chosen according to the support material.

Family (GM2)	Model	Size	Internal code
GM2	-	S	21
Reference to fan-coil sizes			A
Any coding for special versions or new revisions			

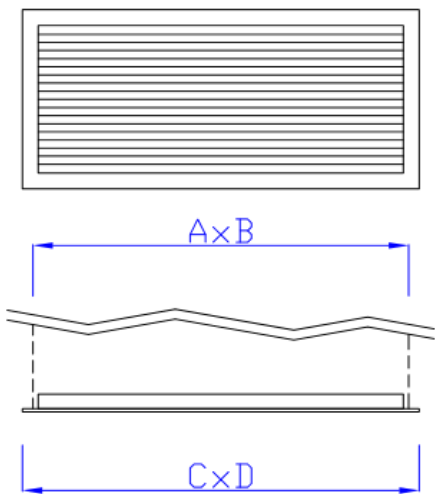

	DIMENSIONS (mm)				
	21	31	38	41	81
A	570	1010	1010	1560	1560
B	240	240	240	300	300
C	602	1042	1042	1592	1592
D	272	272	272	332	332
A, B: nominal hole dimensions					
C, D can vary by +/- 10mm					

9.25-Return grille (GR)

The return grille is made of anodised aluminium. It has fixed horizontal fins, making the inside of the duct barely visible.

The frame is provided with holes for fixing the grille by means of screws (not supplied) which must be chosen according to the support material.

Family (GR)	Model	Size	Internal code
GR	S	21	A
Reference to fan-coil sizes	_____		
Any coding for special versions or new revisions			

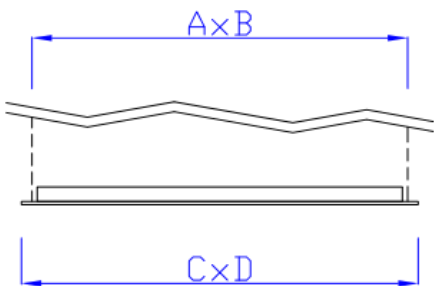
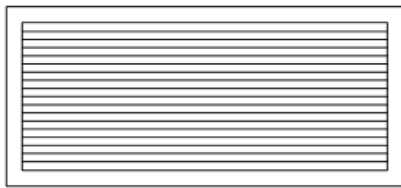

	DIMENSIONS (mm)				
	21	31	38	41	81
A	570	1010	1010	1560	1560
B	240	240	240	300	300
C	602	1042	1042	1592	1592
D	272	272	272	332	332
A, B: nominal hole dimensions					
C, D can vary by +/- 10mm					

9.26-Decorative return grille (GRD)

The decorative return grille is used in the event of exposed (full view) machine installation, to protect or hide the filter from view. It is made of galvanised sheet steel, painted on request.

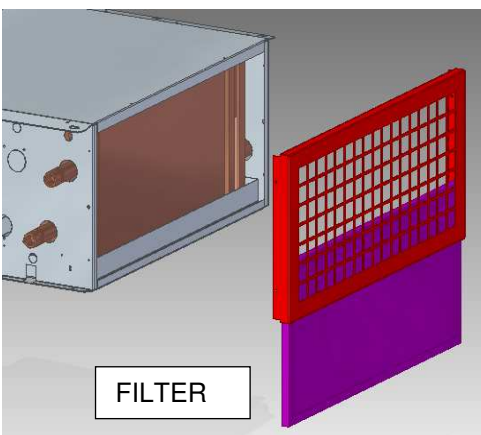
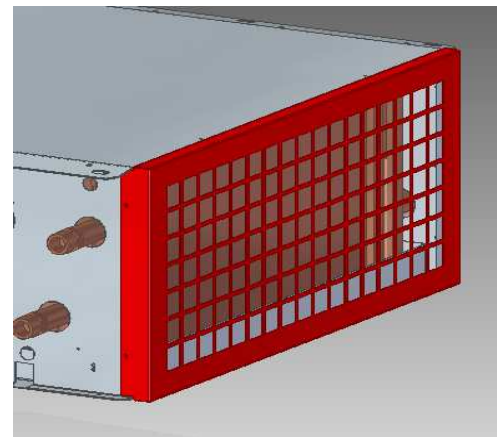
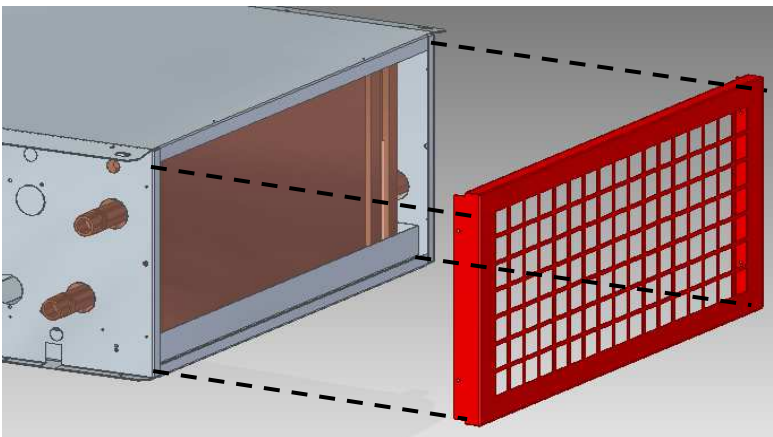
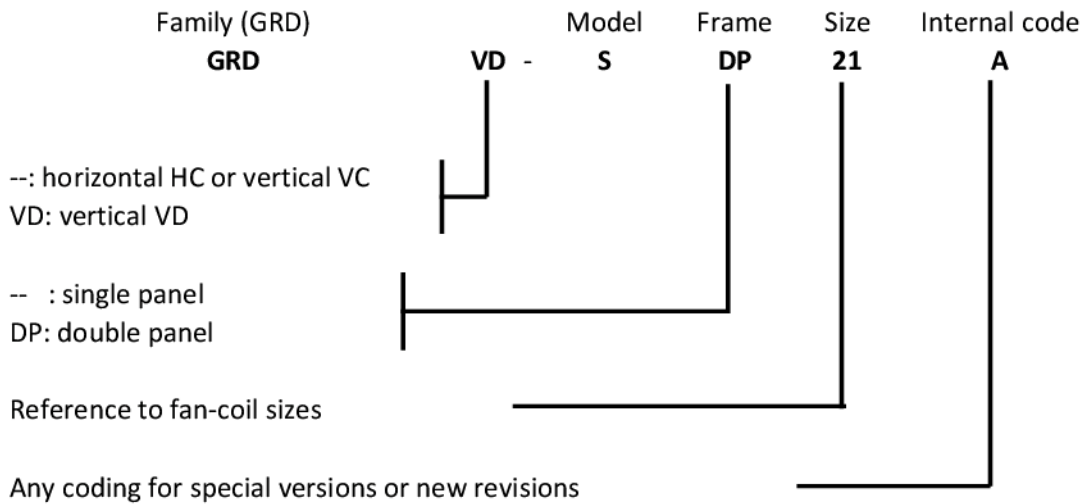

The filter is housed internally (15mm thickness only). By removing the decorative grille (using the special knobs) it is possible to pull out the filter.

9.27-Plenum with delivery grille (PGM2)

The plenum with double-adjustment delivery grille is used to adjust the air flow direction, with exposed machine installation and non-ducted delivery. The delivery grille is made of aluminium and can be used to adjust the flow in the horizontal and vertical directions

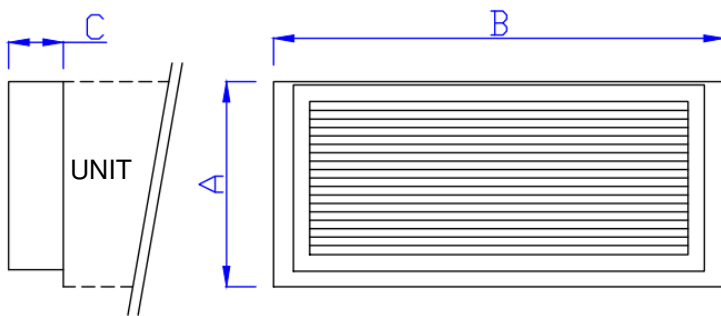
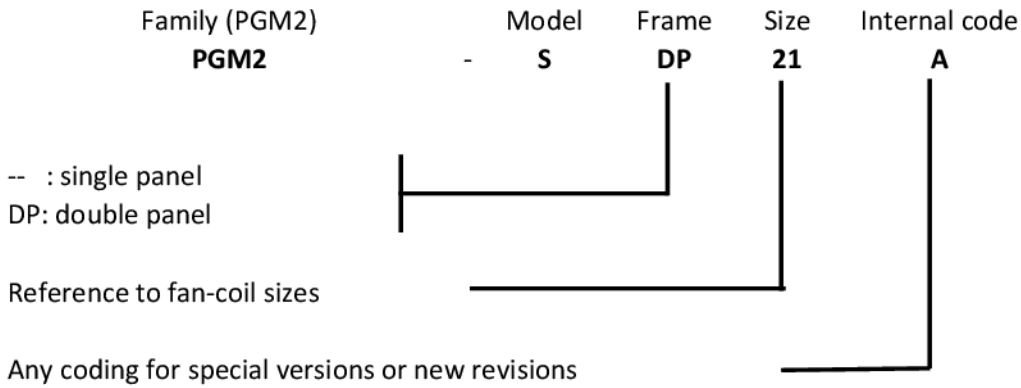

	Single panel unit (SP)				
	DIMENSIONS (mm)				
	21	31	38	41	81
A	300	300	300	375	375
B	660	1100	1100	1650	1650
C	80	80	80	80	80

	Double panel unit (DP)				
	DIMENSIONS (mm)				
	21	31	38	41	81
A	300	300	300	375	375
B	730	1170	1170	1720	1720
C	80	80	80	80	80

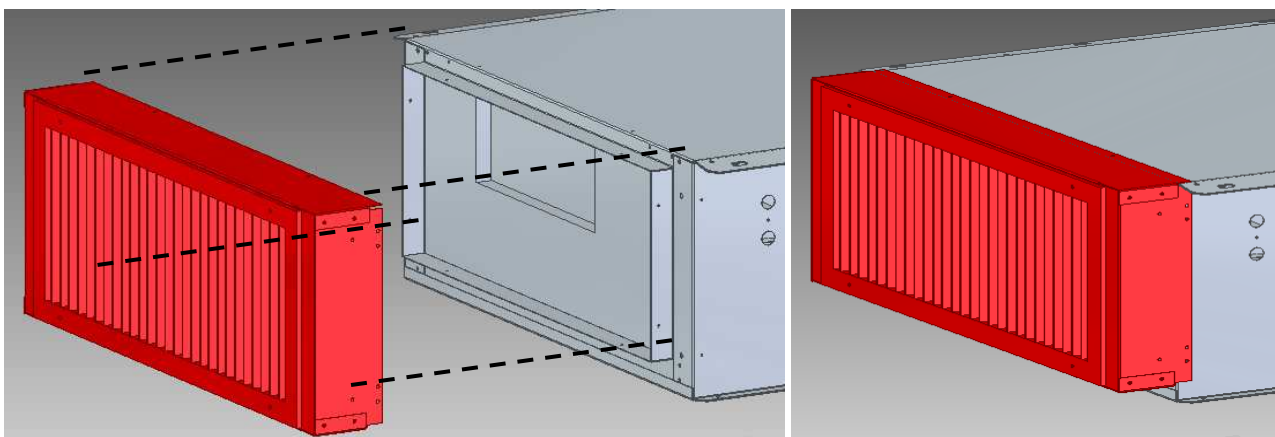

9.28-Plenum with return grille (PGR)

The plenum with return grille is used to hide or cover the filter from view, with exposed machine installation and non-ducted return. The return grille is in aluminium and can contain a 15mm thick filter.

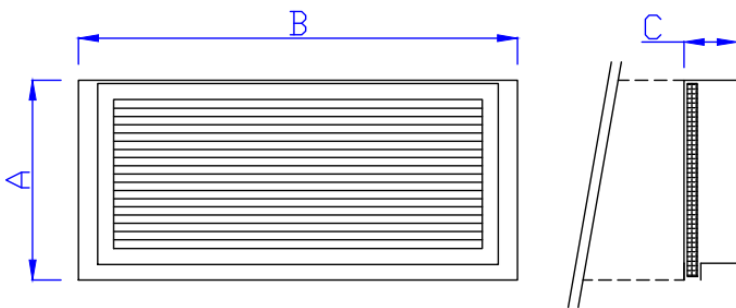
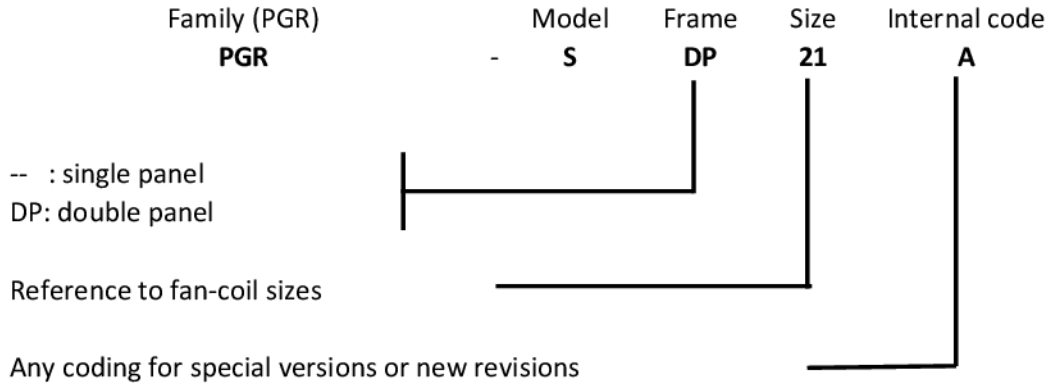

	Single panel unit (SP)				
	DIMENSIONS (mm)				
	21	31	38	41	81
A	300	300	300	375	375
B	660	1100	1100	1650	1650
C	80	80	80	80	80

	Double panel unit (DP)				
	DIMENSIONS (mm)				
	21	31	38	41	81
A	300	300	300	375	375
B	730	1170	1170	1720	1720
C	80	80	80	80	80

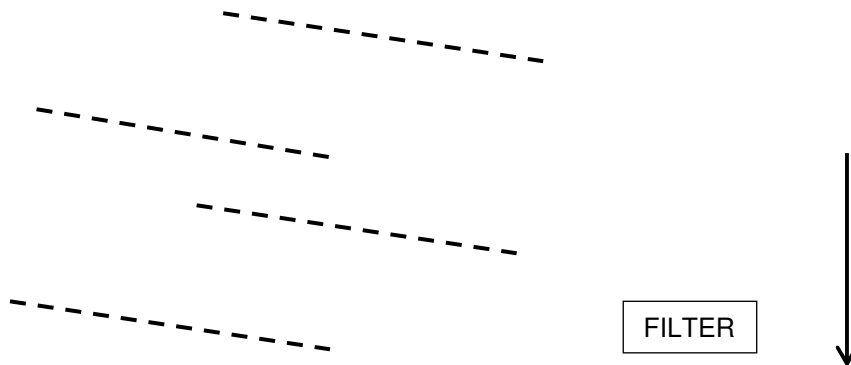

9.29- Insulation for plenum (COIB)

When the plenums are installed on delivery, the COIB accessory must also be added, since the plenums supplied as part of the standard equipment are NOT insulated. The insulation, made of 10mm thick class HF1 polyurethane according to the UL94 standard, prevents condensation from collecting on the outside of the plenum when cold air flows through it.

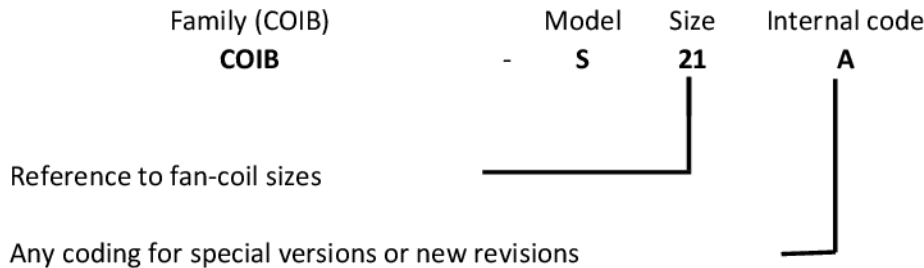

9.30- Duct silencer (SL)

The channel silencer is used when it is necessary to reduce the sound power radiated in the delivery or return channel. Acoustic absorption is obtained by internal insulation with rock wool. For its delivery installation it is also necessary to use the flat flange (FP) and one between the straight plenum (PD) and the 90 ° plenum (P90). The FRA (FRAB, FRAL or FRAV depending on the needs) and the FP flat flange must also be used for its installation on the second floor.

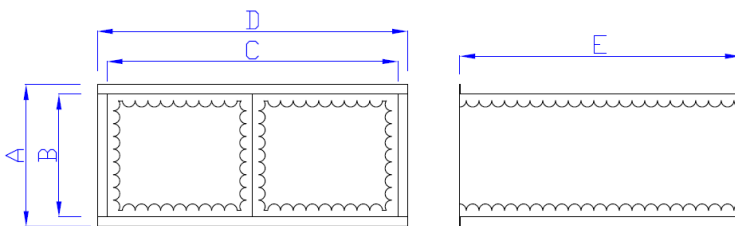
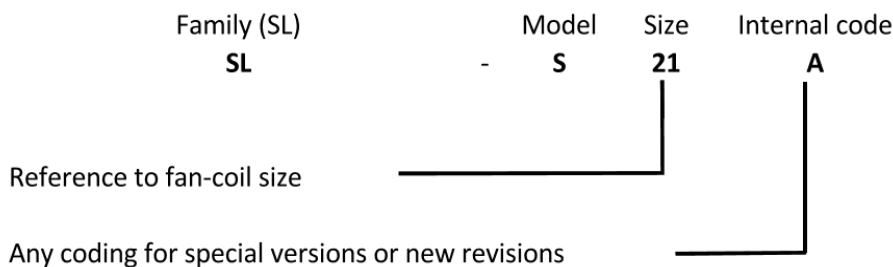

DIMENSIONS (mm)					
	21	31	38	41	81
A	280	300	300	360	360
B	240	240	240	300	300
C	570	1010	1010	1560	1560
D	610	1070	1070	1620	1620
E	600	600	600	900	900

	REDUCTION dB(A)							
	Frequency (Hz)							
	63	125	250	500	1000	2000	4000	8000
21	2	5	10	15	21	20	15	12
31	2	5	10	15	21	20	15	12
38	2	5	10	15	21	20	15	12
41	2	5	11	19	24	19	12	7
81	2	5	11	19	24	19	12	7

	PRESSURE DROP	
	At nominal air flow	
	Pa	
21	9	
31	9	
38	9	
41	6	
81	6	

9.31-Filter (F)

A wide range of filters is available as an alternative to the standard filter (synthetic fibre, 15mm thick, COARSE efficiency according to ISO 16890). All capacity data are referred to a standard filter.

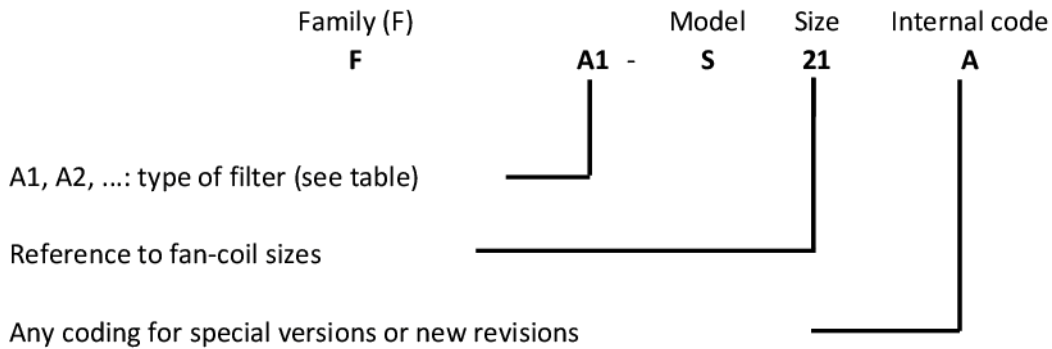

Type	Material (frame)	Material (filter)	Thickness (mm)	Washable (*)	Efficiency (ISO 16890)	dP (**) (Pa)
FA1	Galvanized steel	Polypropylene	6	YES	COARSE (ePM10 <50%)	--
FA2	Galvanized steel	Synthetic fibre	20	NO	ePM10 65%	15
FA3	Galvanized steel	Synthetic fibre	25	NO	ePM10 75%	15
FA4	Galvanized steel	Galvanized steel mesh	15	YES	COARSE (ePM10 <50%)	--
FA5	Galvanized steel	Galvanized steel mesh	25	YES	COARSE (ePM10 <50%)	--
FA6	Galvanized steel	Aluminium mesh	15	YES	COARSE (ePM10 <50%)	--
FA7	Galvanized steel	Aluminium mesh	25	YES	COARSE (ePM10 <50%)	--

(*) If the filter is washable, it is recommended to dry it quickly to avoid the formation of oxides in the metal parts.

(**) Additional pressure drop (approximate value, referred to the maximum nominal air flow) relative to the standard filter

9.32-Air return flange with pocket filter (FRAF6, FRAF7, FRAF8)

The return flange with pocket filter allows the filter to be removed only from the bottom. The pocket filter can be of class F6-F7-F8. The standard filter is moved to the inside of the plenum, upstream from the pocket filter.

The pressure drop of the filter must be deducted from the available pressure head of the base machine. Carefully ensure whether the unit head is such as to overcome the pressure drop of the pocket filter; otherwise, it is advisable to select the high pressure head range (SOFFIO HP).

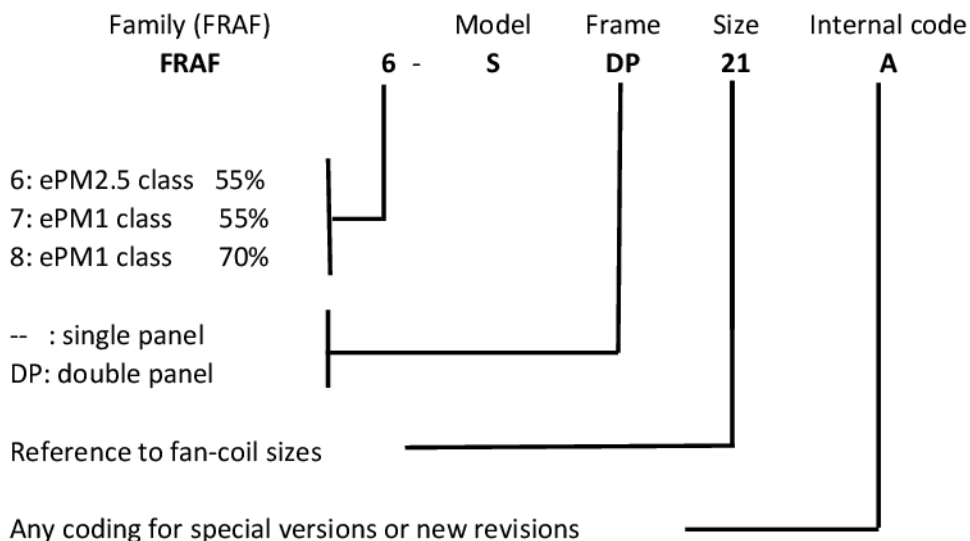

	FRAF6	FRAF7	FRAF8
ISO 16890 class	ePM2.5 55%	ePM1 55%	ePM1 70%
Class EN 779	M6	F7	F8
Suggested final pressure drop	200 Pa	200 Pa	300 Pa
Max pressure drop	450 Pa	450 Pa	450 Pa

SOFFIO 21 POCKET FILTER								
Air flow rate	m3/h	500	600	700	800	900	1000	1100
Pressure drop FRAF6	Pa	20	25	30	35	40	45	50
Pressure drop FRAF7	Pa	30	35	40	45	50	55	60
Pressure drop FRAF8	Pa	40	45	50	55	60	65	70

SOFFIO 31 POCKET FILTER - 38								
Air flow rate	m3/h	800	1000	1200	1400	1600	1800	2000
Pressure drop FRAF6	Pa	40	45	50	60	70	80	90
Pressure drop FRAF7	Pa	45	55	65	75	85	95	105
Pressure drop FRAF8	Pa	50	60	70	80	90	105	120

SOFFIO 41 POCKET FILTER - 81								
Air flow rate	m3/h	1600	2000	2400	2800	3200	3600	4000
Pressure drop FRAF6	Pa	40	45	50	60	70	80	90
Pressure drop FRAF7	Pa	45	55	65	75	85	95	105
Pressure drop FRAF8	Pa	50	60	70	80	90	105	120

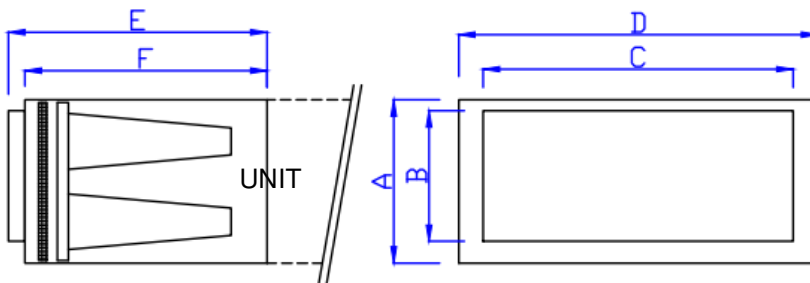

	Single panel unit (SP)				
	DIMENSIONS (mm)				
	21	31	38	81	81
A	300	300	300	375	375
B	240	240	240	300	300
C	570	1010	1010	1560	1560
D	660	1100	1100	1650	1650
E	475	475	475	475	475
F	445	445	445	445	445

	Double panel unit (DP)				
	DIMENSIONS (mm)				
	21	31	38	81	81
A	300	300	300	375	375
B	240	240	240	300	300
C	570	1010	1010	1560	1560
D	730	1170	1170	1720	1720
E	475	475	475	475	475
F	445	445	445	445	445

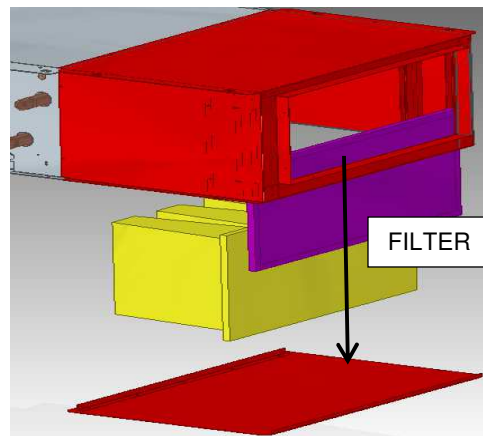
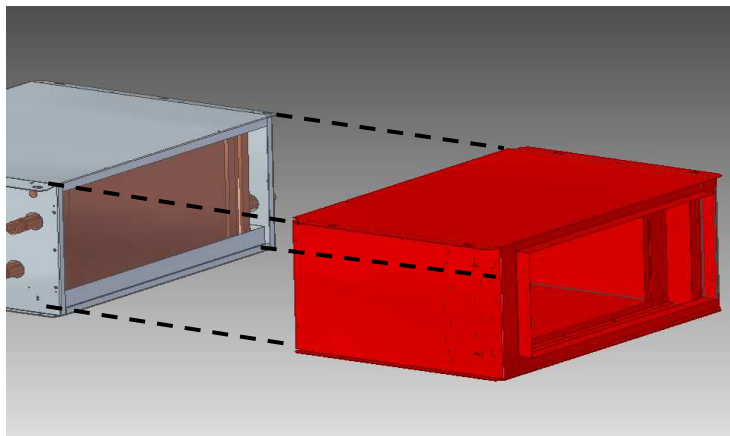

10-Electrical connections

The electrical panel, based on the chosen configuration of the accessories, can consist of a sheet metal box or a plastic box.

Given the wide range of available accessories and their combinations, this manual only shows the wiring diagram of the "basic" unit, i.e. a three-speed AC motor or EC with 0/10V signal and 230V valves.

Each machine is supplied with its specific wiring diagram, based on the chosen equipment.

10.1-AC motor with ETBN 2.5A or ETBN-6A board

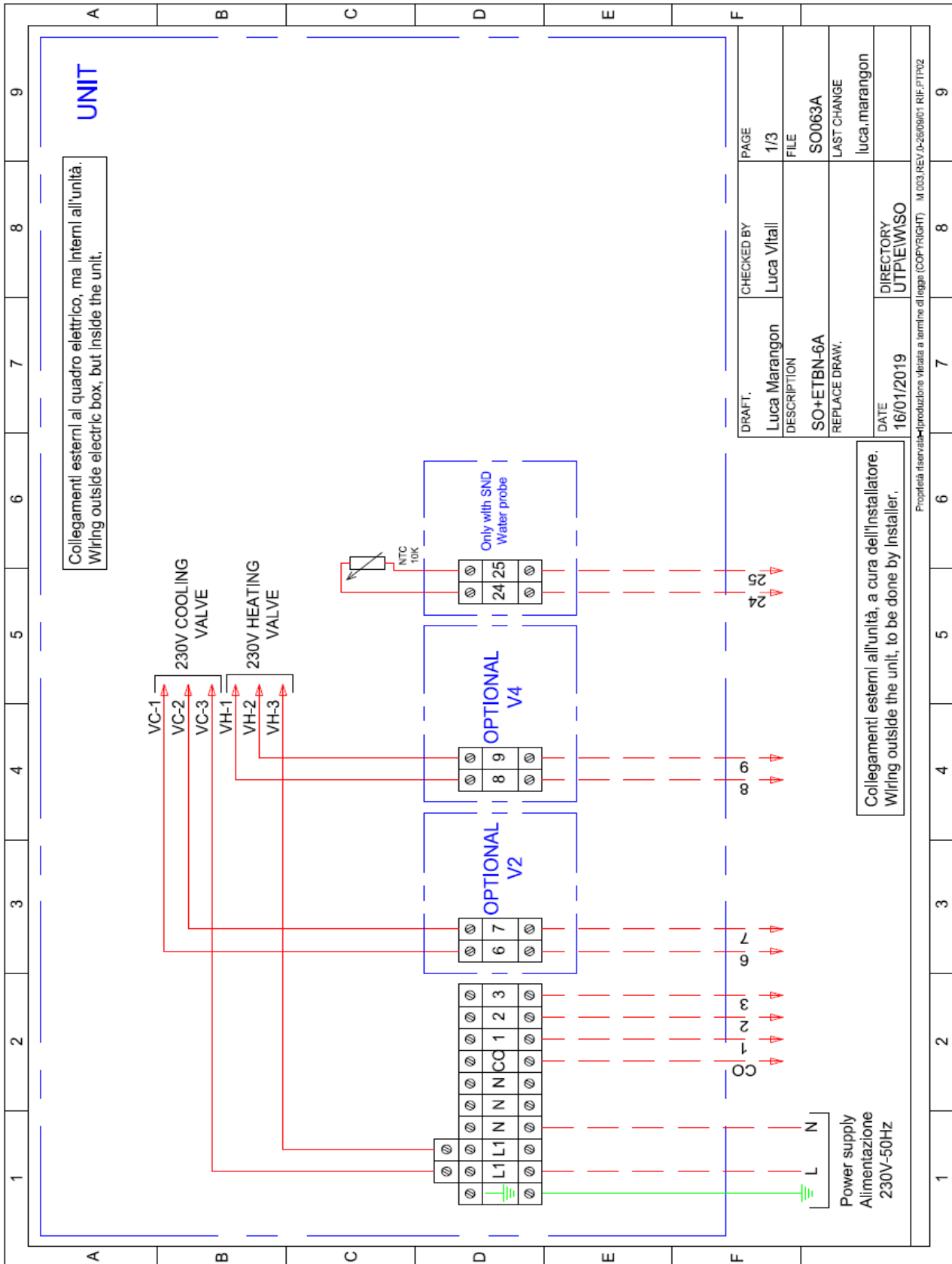

10.2-EC Motor

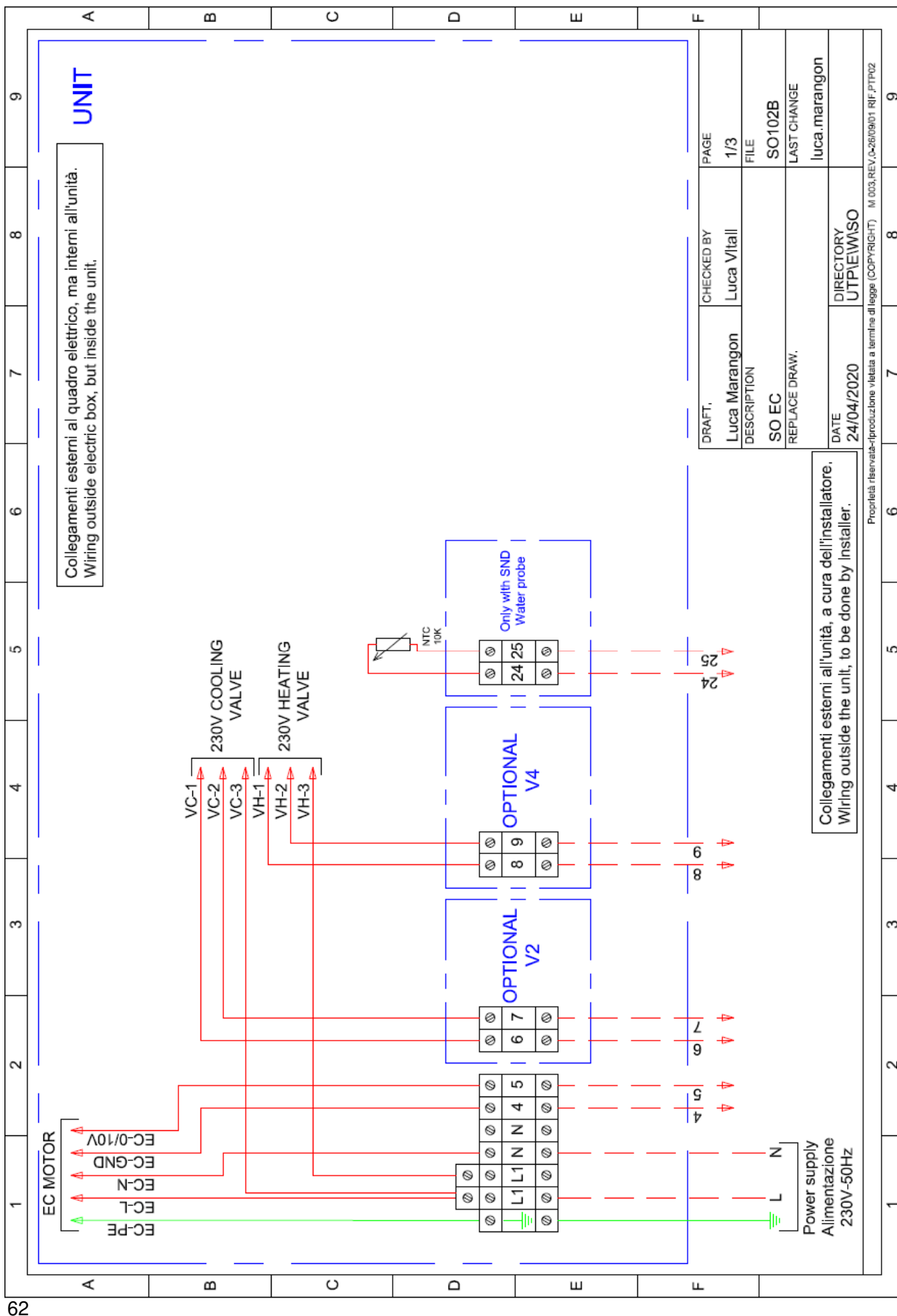

EXTERNAL THERMOSTAT CONTROLS	
CO	Common fan
1	Minimum fan speed (line)
2	Medium fan speed (line)
3	Maximum fan speed (line)
4	Reference with 0-10V signal
5	0-10V signal for motor control
6	Common 2-pipe valve / 4-pipe cold valve (neutral)
7	Common 2-pipe valve / 4-pipe cold valve (line)
8	Common 4-pipe hot valve (neutral) - only if available
9	4-pipe hot valve signal (line) - only if available
24-25	NTC water probe - only if available
26-27	NTC remote air probe - only if available

NOTES:

Aertesi srl reserves the right to introduce any changes considered necessary to improve the product by editing the related technical data at any time



something different

AER.MT.S.GB.008.09.20

Aertesi srl
viale della tecnica, 6/a
35026 Conselve (PD) ITALY
t. +39.049.9501109
f. +39.049.9500823
www.aertesi.com
info@aertesi.com